

Optocoupler

Designer's Guide



About This Designer's Guide

Avago Technologies optocouplers can be used in an array of isolation applications ranging from power supply and motor control circuits to data communication and digital logic interface circuits.

To help you choose and design with Avago Technologies isolation components, this Designer's Guide contains popular application circuits and recommended Avago optocouplers.

This handbook contains sections discussing critical optocoupler design parameters such as Insulation and Withstand Voltage, Regulatory Agency Safety Standards, Common-Mode Transient Rejection, Product Life and light emitting diode (LED) aging. The rest of the guide consists of application circuits.

Each application circuit is accompanied by:

1. A brief description.
2. Highlights of circuit performance.
3. Circuit benefits.
4. A list of alternative Avago parts indicating comparably performing products available in varying package styles for maximum design flexibility.

How to Use This Guide

The table of contents lists all the applications by their general description.

Data sheets for products recommended in this guide can be found on the Avago Technologies' web site at www.avagotech.com/semiconductors, or they may be ordered from your local Avago representative.

How to Order

To order any component in this guide or additional applications information, call your authorized Avago distributor nearest you.

Although product information and illustrations in this guide were current at the time it was approved for printing, Avago Technologies, in a continuing effort to offer excellent products at a fair value, reserves the right to change specifications, designs, and models without notice.

Table of Contents

Design Considerations	1
Insulation and Regulation of Optically Coupled Isolation Devices	1
Common-Mode Transient Rejection	15
LED Degradation Over Time	10
Guidelines for Printed Circuit Board Assembly and Layout	13
Digital Optoisolators: An Overview	14
Digital Logic Interface/Level Shifting Applications	16
TTL Interface with Series LED Drive	16
Level Shifting/TTL Interface with Shunt LED Drive	17
Low Power 8 MBd CMOS Interface	18
25 MBd CMOS Interface	19
Low Power 100 kBd CMOS Interface	20
Isolated 3 V Logic Interface/Battery Operated Applications	21
Data Communication Applications	22
Isolated RS-232C/E Interface	23
Isolated 3.3 V RS-232 Interface	23
Isolated RS-485 Bus Interface	24
Isolated Device Net/CAN Communication Interface	25
Isolated 4 - 20 mA Analog Current Loop Transmitter/Receiver	26
Isolated 20 mA Current Loop Interface	27
Multidrop Line Receiver	28
Isolated Balanced Line Receiver - Circuit No. 1	29
Isolated Balanced Line Receiver - Circuit No. 2	30
Isolated Tri-State Line Driver	31
Isolated Unbalanced Line Receiver	32
PROFIBUS/RS-422 1.5 MB/s	33
Isolated PROFIBUS/RS-485 12 MB/s Communication Application	34
Telecommunications Applications	35
Telephone Ring Detection	35
ISDN Interface	36

Analog Applications	37
High Speed Isolation Amplifier	38
Precision Isolation Amplifier for Unipolar Signals	39
Isolation Amplifier for Bipolar Signals - Circuit No. 1	40
Isolation Amplifier for Bipolar Signals - Circuit No. 2	41
AC-Coupled Isolation Amplifier	42
Isolated Video Interface	43
Motor Control Applications	44
Inverter Design Using Gate Drive and Current Sense Optocouplers	44
Isolated Gate Driver for IGBT/MOSFET	49
Dual Channel Isolated Gate Driver for IGBT/MOSFET	50
Isolated Gate Driver for IGBT/MOSFET with Desaturation Protection	51
Isolated Interface for Intelligent Power Module Gate Drive	52
Low Cost Isolated Phase Current Sensing with Analog Output	53
Isolated A/D Converter for Phase Current Sensing	54
Low Cost Isolated Phase Current Sensing with Analog Output/Over Current Detection	55
Isolated Inverter Rail Voltage Sensing using an Isolation Amplifier	56
Isolated Inverter Rail Voltage Sensing using a Linear Optocoupler	57
Low Cost Isolation Amplifier for Motor Speed and Position Measurement	58
Industrial Applications	59
AC/DC Voltage Threshold Sensing	59
Optical Isolation in Flat-Panel Displays	60
Power Supply Applications	61
Optical Isolation in a Switching Power Supply - Circuit No. 1	61
Optical Isolation in a Switching Power Supply - Circuit No. 2	62
Optical Isolation in a DC/DC Converter	63
Application Notes	64

Insulation and Regulation of Optically Coupled Isolation Devices

The primary purpose of optocoupler devices is to provide both electrical insulation and signal isolation. The popularity of Avago Technologies' product offering can be accredited to cost-effective innovations in these areas. Yet there exists a surprising level of misunderstanding regarding these two terms from both vendor and user alike. The discrepancies that exist within the worldwide regulatory community add to the frustration level for many designers. This discussion attempts to help the designer capitalize on Avago Technologies' knowledge.

Insulation Defined

The electrical insulating capability of an optocoupler, sometimes referred to as withstand voltage, is determined by its ability to protect surrounding circuitry, as well as itself, against physical damage resulting from different voltage potentials. This potentially damaging phenomena can be system induced (e.g., motor rail voltage) or externally coupled (e.g., lightning pulse). The insulating material between input and output as well as the packaging technology are the primary determinants of withstand voltage capability. In contrast, signal isolation, although sharing

some common causes, defines the ability of the optocoupler to prevent the distortion of data through the suppression and filtration of common-mode transients. A further discussion of signal isolation can be found in the section entitled "Common-Mode Transient Rejection."

The effects of repeated long-term high-voltage stress between input and output of an optocoupler has continued to be an area of uncertainty. Much of the technical emphasis has been on the ability of optocouplers to withstand one-time short-term high-voltage transients (e.g., U.L. 1 minute dielectric voltage withstand rating). Avago Technologies has conducted extensive operating life tests to determine the effects of continuous high-voltage stress, both transient as well as steady-state, on the degradation of insulating performance. On completion, the test data was analyzed to determine safe operating areas for steady-state input-output high-voltage stress. The boundary conditions, as shown in Figures 1, 2, 3, have been defined by Avago as Endurance Voltage. The lower region refers to the safe operating area for the application of continuous steady-state ac and dc

input-output voltage stress, or working voltage, and the middle region to transient voltage stress. Operation above these regions has shown to cause wear-out either in functionality or insulating capability and is not recommended. Endurance Voltage is based on the inherent properties of Avago optocouplers that utilize unique packaging technologies and does not apply to products manufactured by other vendors. In addition, as these tests do not take into consideration particular equipment use conditions, Avago recommends the designer consult the appropriate regulatory agency guidelines to determine applicable working voltage. For an in-depth discussion on Endurance Voltage, consult Avago Application Note AN1074.

Regulatory Environment

Because electrical insulation is a function of safety, optocoupler performance, both at component and system levels, is often subject to regulatory requirements and approvals that vary according to country as well as industry. Most agencies are a mixture of governmental and private organizations with industry representation.

INSULATION AND REGULATION

Category 1 Optocouplers

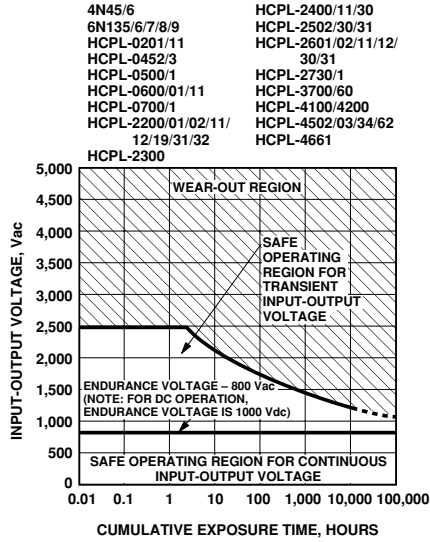

Figure 1. Recommended Safe Operating Area for Input-Output Voltage-Endurance Voltage for Category 1 Optocouplers.

Category 2 Optocouplers:

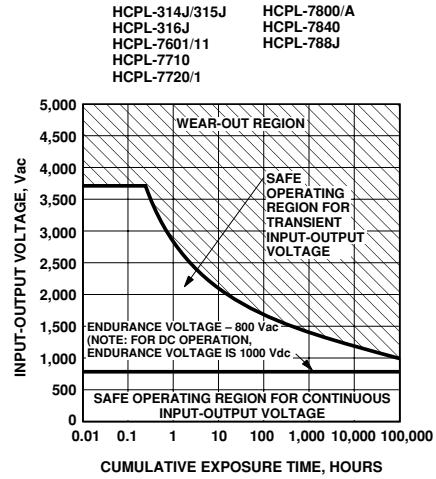

Figure 2. Recommended Safe Operating Area for Input-Output Voltage-Endurance Voltage for Category 2 Optocouplers.

Category 3 Optocouplers:

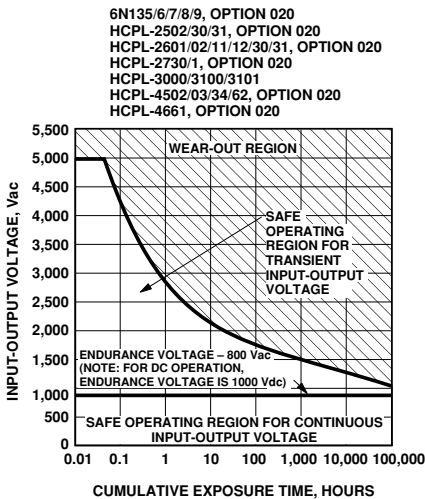

Figure 3. Recommended Safe Operating Area for Input-Output Voltage-Endurance Voltage for Category 3 Optocouplers.

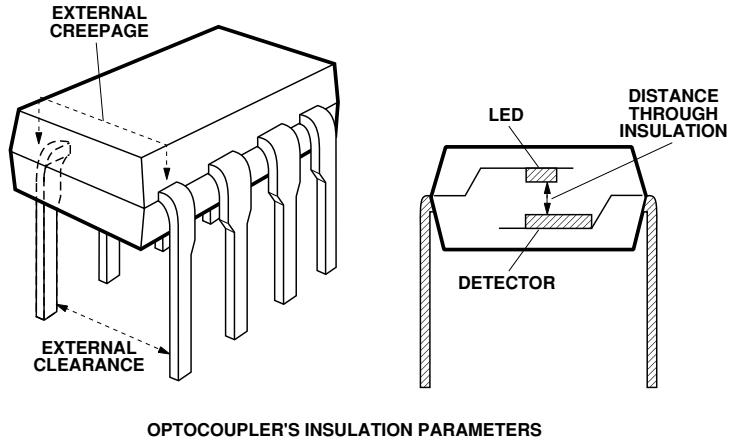

Figure 4. Optocoupler's Insulation Parameters.

WARNING: In all cases where regulatory compliance is required, working voltage as defined by the regulatory agency cannot be exceeded.

INSULATION AND REGULATION

Table 9

COMMON REGULATORY AGENCIES		
Name	Country	Abbreviation
Verband Deutscher Electrotechniker	Germany	VDE
Underwriters Laboratories	United States	UL
Canadian Standards Association	Canada	CSA

Some common regulatory agencies are listed in Table 9.

Currently, little conformity exists between the various agencies regarding mechanical configurations and electrical test requirements. Within the European Union, however, standardization of equipment as well as component level specifications is in progress. In the interim, testing and approval according to equipment type and environmental factors must be obtained according to the control documents of each country. The International Electrotechnical Commission (IEC), with worldwide representation, provides a forum for generating technical standards. The European Committee for Electrotechnical Standardization (CENELEC), has European Commission authority to adopt IEC standards as European Norms (EN), with the force of law.

Common Terms

External Clearance

The shortest distance through air, between conductive input and output leads, measured in mm. Refer to Figure 4.

Comparative Tracking Index (CTI)

Outer molding material characterization in the presence of aqueous contaminants. The higher the CTI value, the more resistant the material is to electrical arc tracking. CTI is often used with creepage by safety agencies to determine working voltage.

External Creepage

The shortest distance along the outside surface, between input and output leads, measured in mm. Refer to Figure 4.

Dielectric Insulation Voltage Withstand Rating

The ability to withstand without breakdown a 60 second application of a defined dielectric insulation voltage between input and output leads.

Distance Through Insulation

Distance between the photo-emitter and photodetector inside optocoupler cavity (also called internal clearance). Refer to Figure 4.

Installation Class

- I Equipment in closed systems (e.g., telecom) protected against over-voltage with devices such as diverters, filters, capacitors, etc.
- II Energy consuming equipment (e.g., appliances) supplied through a fixed installation.
- III Primarily equipment in fixed installations (e.g., fixed industrial equipment).
- IV Primary supply level for industrial factories.

Insulation

Operational - required for correct equipment operation but not as a protection against electric shock.

Basic - protects against electric shock.

Supplementary - independently applied to basic insulation to protect against shock in the event of its failure.

INSULATION AND REGULATION

Double - composed of both basic and supplementary.

Reinforced - A single insulation system composed of several layers (e.g., single and supplementary).

Internal Clearance

See Distance Through Insulation.

Internal Creepage

The shortest border distance between two separate insulating materials measured between emitter and detector.

Material Group (see Comparative Tracking Index)

I 600 < CTI

II 400 < CTI < 600

IIIa 175 < CTI < 400

IIIb 100 < CTI < 175

Partial Discharge

Electric discharge that partially bridges the insulation between two electrodes. Avago supports partial discharge measurements per IEC/EN/DIN EN 60747-5-2, a technique developed to evaluate the integrity of insulating materials. IEC/EN/DIN EN 60747-5-2 philosophy is that partial discharge testing offers advantages over Dielectric Withstand Voltage testing, which might adversely affect the insulating material, and over through insulation distance requirements which not only increase manufacturing costs but also do not necessarily result in acceptable insulating capability.

Pollution Degree

1 - Nonconductive pollution only.

2 - Only occasional, temporary conductivity due to condensation.

3 - Frequent conductive pollution due to condensation.

4 - Persistent conductive pollution due to dust, rain or snow.

Rated Mains Voltage

Primary power voltage

declared by manufacturer.

Used to categorize optocoupler maximum allowable working voltage.

INSULATION AND REGULATION

Common-Mode Transient Rejection

Circuit designers often encounter the adverse effects of common-mode noise in a design. Once a common-mode problem is identified, there are several ways that it can be resolved. However, common-mode interference manifests itself in many ways; therefore, it may be hard to determine whether it is the cause of a circuit's misbehavior. If a system is connected and running but only produces erroneous data, common-mode noise may be the reason. This section describes sources of common-mode problems, presents possible solutions, and highlights the technology that Avago Technologies' Components Group uses to produce optoisolators with superior Common-Mode Performance.

Common-mode rejection (CMR) is a measure of the ability of a

device to tolerate common-mode noise. Avago specifies common-mode rejection as **common-mode transient rejection (CMTR)**. CMTR describes the maximum tolerable rate-of-rise (or fall) of a common-mode voltage (given in volts per microsecond). The specification for CMTR also includes the amplitude of the common-mode voltage (V_{CM}) that can be tolerated. Common-mode interference that exceeds the maximum specification might result in abnormal voltage transitions or excessive noise on the output signal. (CMTR is slightly different than common-mode rejection ratio **CMRR**, often used for analog devices and commonly specified in dB as the ratio of the differential-mode gain to the common-mode gain.)

Avago optocouplers rely on two key technical strengths to achieve

high CMTR. The first is use of a proprietary, low-cost Faraday shield which decouples the optocoupler input side from the output side. The second method is by unique package design which minimizes input-to-output capacitance. The importance of these two strengths is explained as follows.

Figure 5 illustrates a Common-mode transient pulse (V_{CM}).

Figure 6a and 6b show interference circuit models for two types of possible common-mode failure mechanisms for a single-transistor optocoupler. The dashed lines are shown to indicate external components added to the optocoupler. V_{CM} represents a voltage spike across the optocoupler isolation path between the output-side ground (V_{G2}) and input-side ground (V_{G1}). V_{DM} represents a signal voltage applied across the input side.

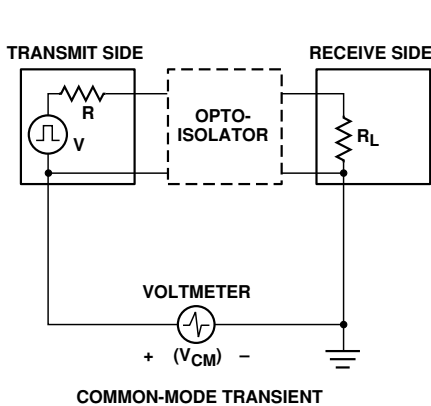

Figure 5. Illustration of V_{CM} Common-Mode Pulse.

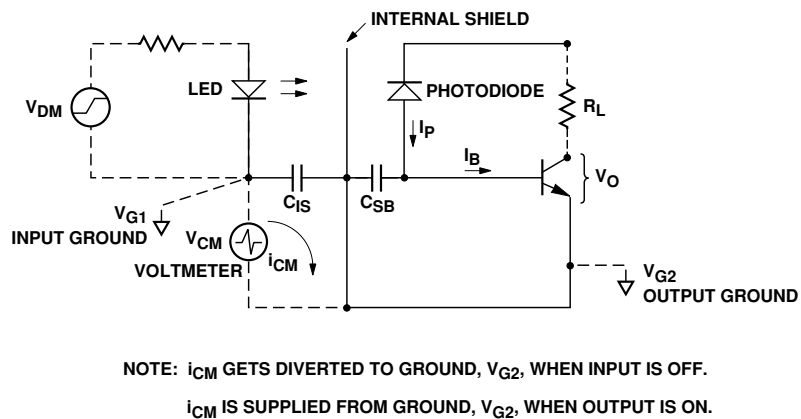
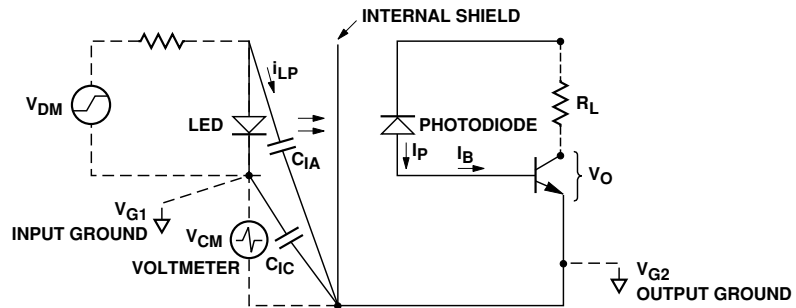

Figure 6a. Interference Circuit Model.

COMMON-MODE TRANSIENT REJECTION

Referring to Figure 6a the parasitic distributed capacitance C_{IS} , which might tend to couple transient current into the transistor base node (for example when the transistor is in the “off” state) terminates on an internal Faraday shield. Therefore the transient current, I_{CM} , gets diverted to output ground (V_{G2}). Referring to Figure 6b, the parasitic distributed capacitances, C_{IA} and C_{IC} are shown across the LED anode-to-ground (V_{G2}) and LED cathode-to-ground (V_{G1}) respectively. Because the LED anode is at a relatively higher impedance than the cathode (i.e., R_{LED} to ground) current at this point will tend to be modulated slightly during CM transients. For instance, if the LED is on, then during a positive transient (i.e., $dV_{CM}/dt > 0$) current will be diverted away from the LED. For fast enough transients, this may turn the LED off. (If R_{LED} is connected to the LED cathode side then C_{IC} provides a parasitic path to divert current towards or away from the LED.) This type of failure is avoided by ensuring that C_{IA} and C_{IC} are small.



NOTE: CURRENT “STOLEN” FROM LED: $i_{LP} = C_{IA} \frac{dV_{CM}}{dt}$

Figure 6b. Interference Circuit Model.

Figure 7 shows the possible effect on the output voltage level of an optocoupler due to a common-mode pulse. The output

is shown (successively) in the high and low states. (This might be observed if R_{led} were connected as in Figures 6a, 6b.)

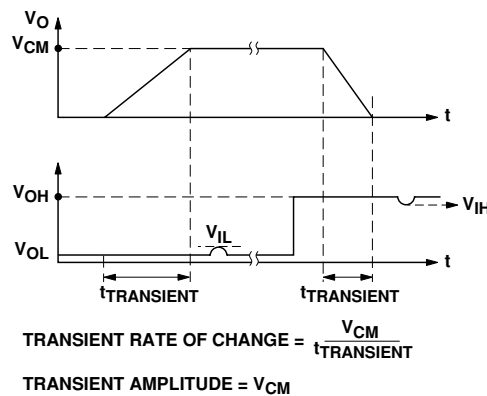

Figure 7. Common Mode Interference Effect.

COMMON-MODE TRANSIENT REJECTION

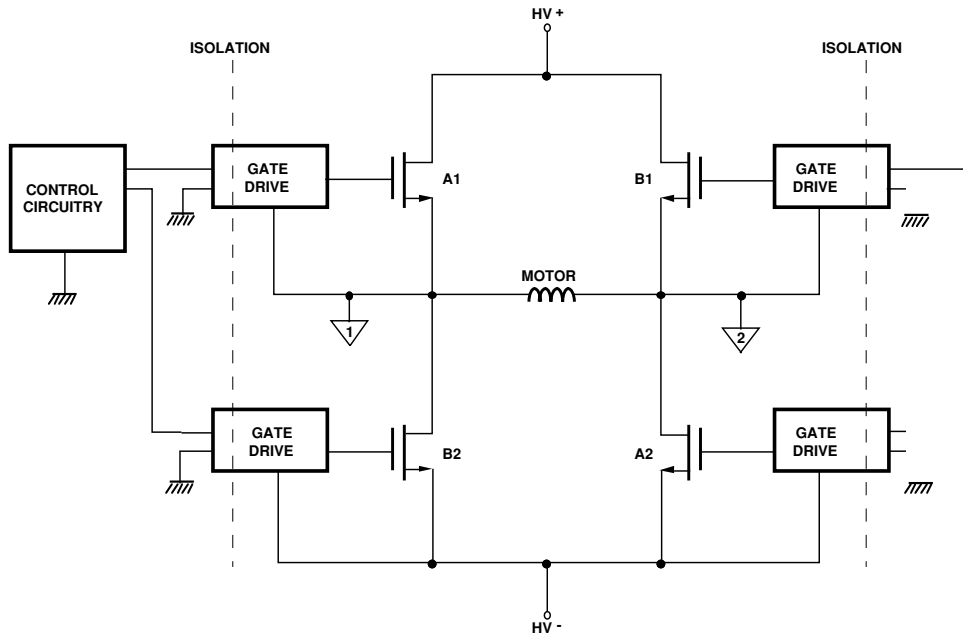

Figure 8. Full-Bridge Power Switch Configuration.

As long as the amplitude V_{CM} and value of dV_{CM}/dt are less than the ratings for the optocoupler being used, V_{OH} will remain above 2 V (maximum TTL V_{IH}) and V_{OL} will remain below 0.8 V (minimum TTL V_{IL}). Note that the slight perturbations in output voltage occur sometime after the input pulse which causes them, due to the non-zero response time of the output transistor to the “perturbation signal.”

Common-mode signals can originate from several different sources. A full bridge power inverter, shown in Figure 8, is a good example of an application that can exhibit large amounts of common-mode noise. Full-bridge inverters are commonly found in motor-speed control and switching power supply applications. The power inverter is generally used to produce an ac output from a dc input. In a full-bridge inverter application like that shown in Figure 8, the source of one set of

transistors (A1, B1) is attached to the drain of a second set of transistors (A2, B2). When transistor set A turns on, set B turns off. Current flows from the positive supply, through transistor A1, through the load, and through transistor A2. When set B turns on, set A turns off, and the polarity of the current through the inductive load is reversed.

How does this operation create a common-mode problem? The input of each gate drive circuitry is referenced to the ground of the digital control circuitry; the output common, on the other hand, is floating and referenced to the source of its associated power transistor. The floating commons of the upper gate drive circuits rapidly switch between the positive and negative power supplies. This rapid switching creates a large voltage swing across the input to output of the gate drive circuitry. As an

example, a half bridge circuit that switches between +250 V and -250 V in 100 ns creates a common-mode transient signal of 5000 V/ μ s with an amplitude of 500 V (see Figure 9). The device that carries the control information to each MOSFET must be able to withstand this level of common-mode interference. Although this example may seem extreme, it is a fact that engineers continue to use faster-switching transistors to increase motor efficiency. Power MOSFETs, for example, are commonly used in power inverter applications because they are capable of high frequency, high power switching. The fast switching speeds of the transistors, however, can generate common-mode signals with very high rates of change (dV_{CM}/dt).

The common-mode signal rate of rise can also be affected by the reverse recovery characteristics of diodes D1 and D2 in the power

COMMON-MODE TRANSIENT REJECTION

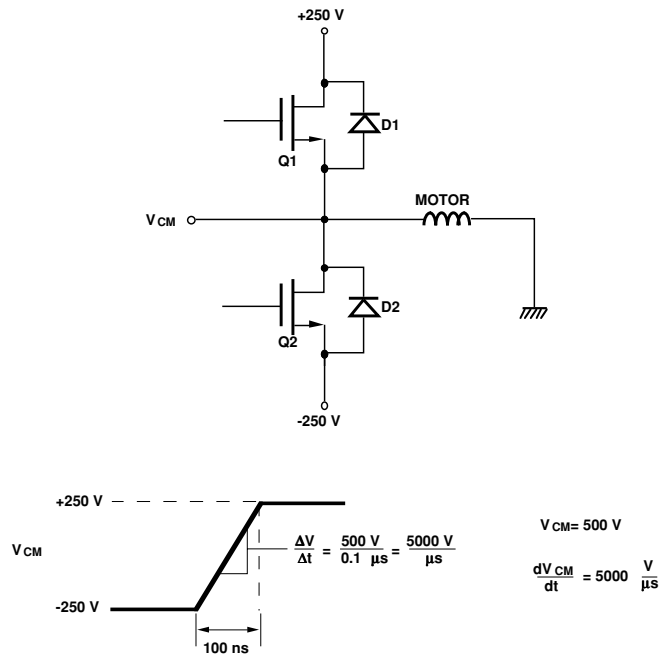

Figure 9. Half-Bridge Example.

inverter shown in Figure 9; these diodes are often referred to as “freewheeling” diodes. If the inverter is driving an inductive load, such as a motor winding, these diodes may become forward biased during the normal operation of the inverter. For example, assume that Q1 of Figure 9 is turned on, Q2 is off, and current is flowing through Q1 and into the inductive load. When Q1 turns off, voltage V_{CM} swings in the negative direction until diode D2 becomes forward biased and conducts the load current.

It is when Q1 turns back on that very high rates of rise can be generated. In extreme cases, when Q1 turns on again, the rate of rise of voltage V_{CM} is determined by how quickly diode D2 recovers from forward conduc-

tion. The voltage and current waveforms shown in Figure 10 illustrate what happens when Q1 turns back on. As Q1 starts to turn on, the current through D2 begins to decrease. The current through D2 continues to decrease and actually goes negative for a short time due to the storage of minority carrier charge in its junction. It is when this charge has been depleted that D2 begins to turn off and V_{CM} begins to increase. If D2 turns off very quickly, V_{CM} can also rise very quickly, generating a large common-mode transient signal.

For the particular case of driving the gate of an IGBT or power MOSFET in a power inverter, the HCPL-3120 IGBT/MOSFET gate drive optical isolator is an effective solution for common-

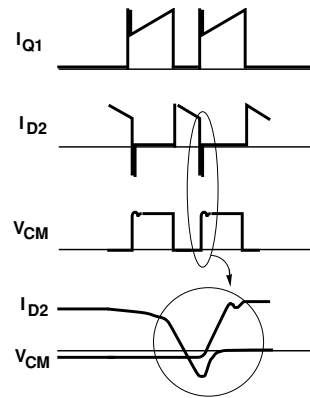

Figure 10. Half-Bridge Inverter Waveforms.

mode problems, providing protection against common-mode transients with slew rates as fast as 15 kV/μs at V_{CM} as high as 1500 V.

High electrical noise levels can also contribute to common-mode problems. A significant amount of electrical noise is found in industrial environments as a result of the starting and operating of electric motors. When a large motor first turns on, it normally requires a large in-rush current to reach operating speed. This large current spike can generate a significant amount of electrical noise in its own and nearby systems. Even the electric motors in a typical household environment vary in size from fractional to low integral horsepower units and are often noisy ac-operated or brushed dc-motors. Other sources of electrical noise include microwave ovens, welding equipment, and automobile ignitions.

Common-mode noise can enter a system through conductive, inductive, or capacitive coupling. An example of a “conducted”

COMMON-MODE TRANSIENT REJECTION

noise voltage is the difference in ground potential that may exist between two connected systems in a plant. The two systems may experience a small voltage difference between their ground references. This voltage difference might cause a ground-loop current to flow. If the impedance of the path through which the ground-loop current flows is large enough, a significant amount of interference will result. Capacitive or inductive coupling may occur when signal wires run close to ac power cables. Electromagnetically induced interference (EMI) can also be coupled from adjacent signal lines or nearby equipment, especially in factory environments. Other sources of common-mode noise that can be coupled into a system include lightning strikes and electrostatic discharge (ESD).

Optical isolation is a useful technique for reducing common-mode interference. Optocouplers, like transformers and capacitively-coupled devices, provide isolation between the input and output of a system. Transformers, by virtue of their high primary-to-secondary capacitance, tend to have lower CMTR capability. Capacitively-coupled devices tend to have poor CMTR capability (since in these devices fast, transient common-mode pulses pass across the coupling capacitor and are not filtered out.) Optocouplers, having low input-

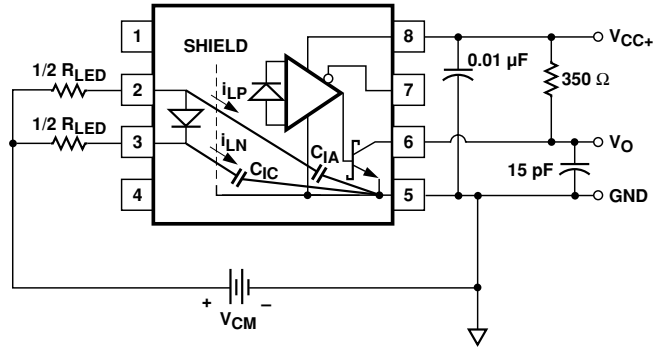

Figure 11. AC Equivalent Circuit for HCPL-261X.

to-output capacitance, typically provide better common-mode rejection than transformers or capacitively-coupled devices. The CMR specification of an optocoupler ranges up to $V_{CM} = 1500$ V amplitude and up to $15,000$ V/ μ s rate of change of V_{CM} , for high-CMR products.

Another advantage of optocouplers lies in the area of EMI generation and susceptibility. Transformers typically radiate electromagnetic interference (EMI) and are susceptible to magnetic fields. Capacitively-coupled devices generate ground-loop current, thus generating EMI. Optocouplers use light for data transmission; additionally, they effectively eliminate ground-loop current. Therefore, they do not radiate nor are they affected by stray magnetic fields. This ability is well-recognized in the

European Community where systems designers need to achieve system-level standards (now adopted as EN50081/EN50082 which set limits on the amount of acceptable EMI a system radiates or to which it is immune.)

A technique which may be used to further enhance CMTR is an “LED split-resistor” technique as shown in Figure 11; (note that the V_{DM} which would appear between the top and bottom R_{LED} s has not been shown in this “ac equivalent circuit”). By using two LED-resistors (instead of one) the current change at the anode of the LED is nearly canceled by the current change at the cathode, thus tending to keep the LED current constant. This makes the optical isolator more immune to CM transients where C_{LA} and C_{LC} limit CMTR.

LED DEGRADATION

LED Degradation over Time

One concern for optocoupler lifetime is that LED light-output (LOP) decreases over time. Generally, light-output degradation gets worse with increasing operating temperature and operating LED current. A worst-case scenario is that over time, as the LED becomes dimmer, the LOP will fall below the minimum value needed for a part to switch properly. Avago Technologies, an industry leader in LED technology, tests LOP degradation under accelerated conditions in order to provide designers with information on the expected operating lifetime of optocouplers. Optocouplers which have an input driver IC are designed such that the driver IC sets the proper input I_F , guardbanding for expected LED LOP degradation over the life of the optocoupler. (Examples are the HCPL-3700, HCPL-7101, and HCPL-7840.) On the other hand, optocouplers requiring an input current-setting resistor (i.e., without an input driver IC)

require that the circuit designer guardband the minimum recommended operating I_F by an amount sufficient to account for expected LOP degradation.

Avago has undertaken testing of LED degradation for periods of continuous operation up to at least 10 khours for various LEDs used in Avago optocouplers. Figures 12a and 12b show the normalized light output over a 10,000 hour period for Gallium Arsenide Phosphide (GaAsP) and Aluminum Gallium Arsenide (AlGaAs) LEDs respectively.

Figure 13 shows LOP as a function of I_F for a GaAsP LED under operating conditions of $I_F = 20$ mA at an ambient temperature of $T_A = 125^\circ\text{C}$. Curves are shown for $t = 0$ hours and $t = 10$ khours of continuous operation.

Optocouplers which use the GaAsP and AlGaAs LEDs are listed in Figures 12a and 12b.

Figure 14 illustrates how, based on knowledge of initial and post-stress LOP vs. I_F , (for a GaAsP LED) a minimum guardbanded I_F can be determined to provide for LOP degradation over the life of the LED. For this case, the minimum recommended I_F at $t = 0$ hours ($I_{F(\text{min})}$) of 5 mA is guardbanded for 10 khours of operation to a value of 6.1 mA.

Note that in Figure 14 if the LOP vs. I_F curves were linear over the range between $I_{F(\text{min})}$ and $I_{\text{GB}(\text{min})}$ (minimum I_F guardbanded for $t = 10$ khours) then the amount of guardbanding (percent change) would be equal to the amount of LOP degradation (percent change). Since in our case the curve is “concave up” the amount of guardbanding is slightly less than the percent change in LOP between $t = 0$ and $t = 10$ khours. Figure 15 (which is a plot of the slope of the $(t = 0)$ curve in Figure 14), shows that the slope is increasing up to about $I_F = 20$ mA, at which point it

LED DEGRADATION

flattens out and begins decreasing.

By empirically modeling the typical GaAsP LOP vs. I_F curve and applying knowledge of worst-case (-3 σ) degradation over time, guardbanded $I_{GB(min)}$ for a typical LED can be reduced to the following equation:

$$I_{GB(min)} = \frac{I_{F(min)}}{\delta^{\frac{1}{\alpha}}}$$

$$\approx I_{F(min)} \times 1.214$$

where,

$I_{F(min)}$ = minimum recommended I_F at $t = 0$ hours.

$I_{GB(min)}$ = minimum guardbanded I_F after $t = 10$ khours.

$\alpha = 1.3$ (empirical curve - fit)

δ = Post-stress LOP Factor

(≈ 0.784 for 10 khours,

$T_A = 125^\circ\text{C}$, $I_F = 20 \text{ mA}$)

This equation applies well when I_F is approximately constant.

Example: To calculate the appropriate $I_{GB(min)}$ for an HCPL-3120 note that $I_{F(min)} = 7 \text{ mA}$. Applying the above relationship for 10 khour guardbanding, $I_{GB(min)} = 8.50 \text{ mA}$.

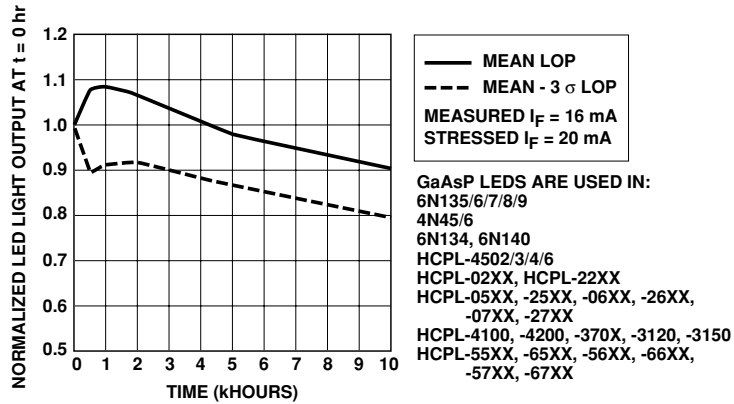

Figure 12a. Normalized LED Light Output (LOP) vs. Time for GaAsP LED (Stress $I_F = 20 \text{ mA}$, $T_A = 125^\circ\text{C}$).

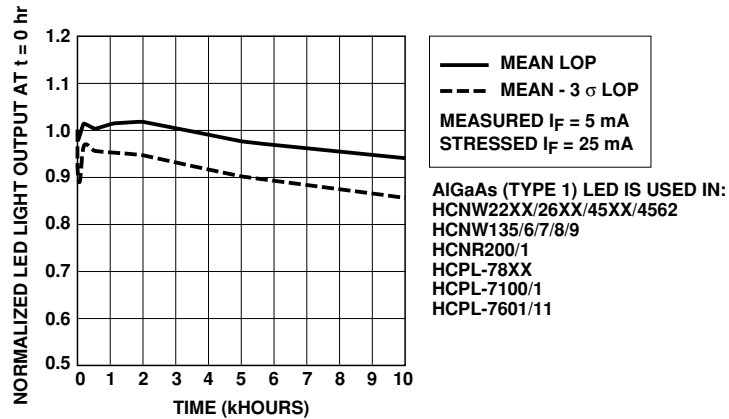

Figure 12b. Normalized LED Light Output (LOP) vs. Time for AlGaAs LED (Stress $I_F = 25 \text{ mA}$, $T_A = 125^\circ\text{C}$).

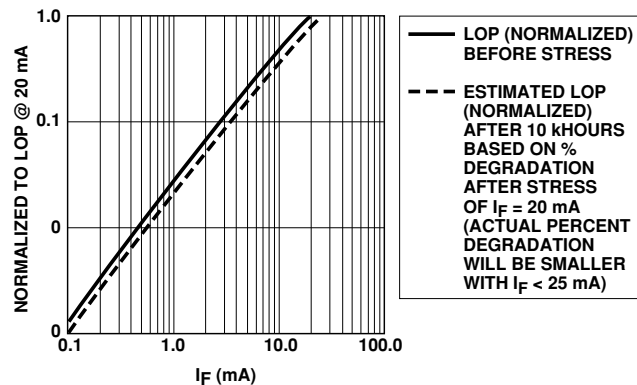

Figure 13. Typical GaAsP LED Light-Output (LOP) vs. I_F After 0 khours and 10 khours of Continuous Operation at 125°C , $I_F = 20 \text{ mA}$.

LED DEGRADATION

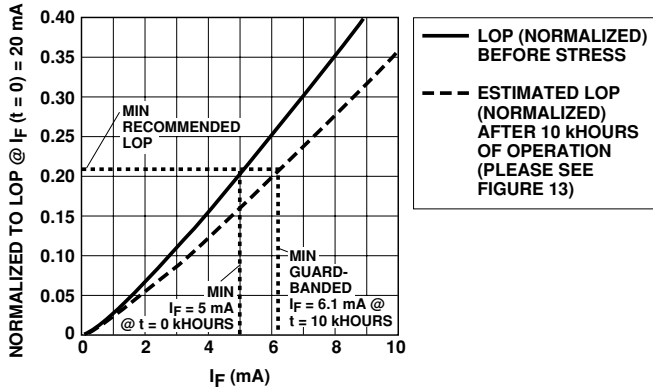

Figure 14. GaAsP LED Light Output (LOP) vs. I_F on a Linear Scale (Stressed at $T_A = 125^\circ\text{C}$, $T_F = 20\text{ mA}$).

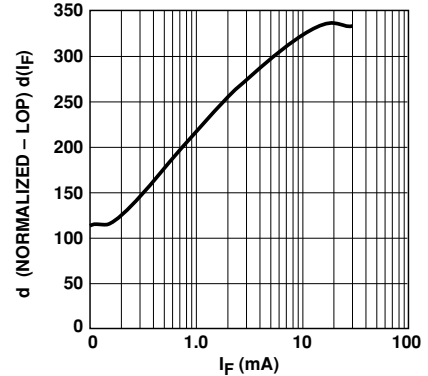

Figure 15. Slope of Typical GaAsP LOP vs. I_F .

Factors which will increase expected LED guardbanded-operation times are:

1. **Operation at lower I_F :** LOP decreases less with reduced operating I_F . Therefore, operation at $I_{GB} < I_F < 20\text{ mA}$ will result in guardbanded operating lifetimes longer than 10 khours. This is due to the fact that lower operating I_F reduces junction temperature (T_J) which subsequently reduces the amount of degradation over time. Generally, the lower

the operating I_F , the lower the percent degradation will be as a function of time.

2. **Operation at Duty Factor (DF) less than 100%** will increase guardbanded operating lifetimes. For any particular duty factor, the new guard-banded lifetime becomes:

$$\frac{\text{lifetime}_{\text{continuous}}}{\frac{DF(\%)}{100}}$$

3. **Operation at ambient temperature $T_A < 125^\circ\text{C}$** will also decrease the amount of LOP degradation (again, due to decreased T_J) increasing operation lifetime.

Avago also has LED degradation data available for other LED types. AlGaAs LEDs tend to be more linear than GaAsP LEDs and display less degradation over time than GaAsP. Therefore the calculations used here can be applied with confidence to optocouplers using AlGaAs LEDs. For further specific questions, please contact your local Avago Technologies' sales representative.

LED DEGRADATION

Guidelines for Printed Circuit Board Assembly and Layout

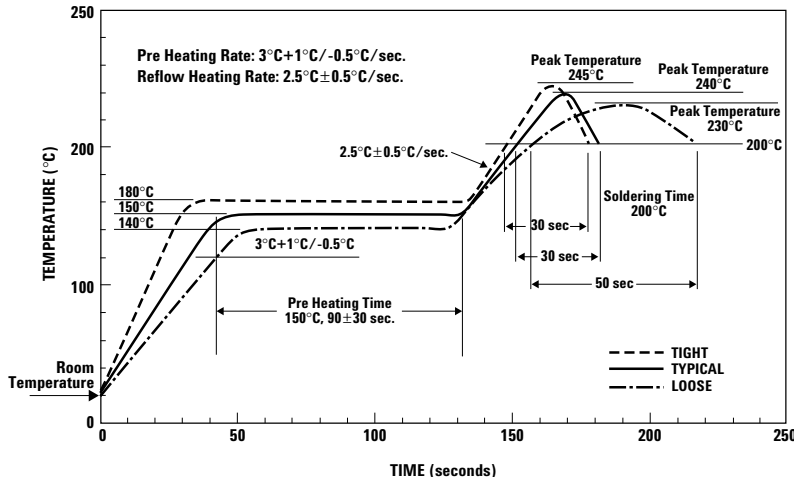

Figure 16. Temperature/Time Thermal Profile.

Avago optocouplers are suitable for automatic printed circuit board (PCB) assembly operations including surface mount assembly. The following guidelines are recommended for proper operation and long term reliability of Avago optocouplers.

Solder Reflow Process: Only one soldering operation is recommended within the thermal profile shown in Figure 16. With infrared lamp heating, use precautions to avoid localized temperature rise in the resin. Also, the resin should not be

immersed in the solder. To prevent chloride corrosion of the lead frame, halide fluxes should not be used.

Wave Soldering: The maximum solder temperature allowed is 260°C for 10 seconds, with the solder 1.6 mm below the seating plane.

Solvent Cleaning: The solvent temperature and immersion time should not exceed 45°C and three minutes respectively. For ultrasonic cleaning, environmentally safe solvents such as ethyl and methyl alcohol are recommended.

ESD Precautions: Standard electrostatic discharge precautions should be taken in handling and assembly of the optocouplers to prevent damage or degradation of the device.

Printed Circuit Board Layout: An optocoupler performs reliably only in a correctly designed circuit. In most digital optocouplers the amplifier at the output is required to operate with the very low photocurrent from the photodetector. Consequently these amplifiers can be sensitive to electrical disturbances. It is therefore necessary to have proper shielding and bypassing of the V_{CC} and Ground traces. Bypassing closely to each of the optocouplers V_{CC}-to-Ground pins with low-inductance ceramic capacitor is recommended as shown in Figure 17.

Figure 17 shows an optional PCB layout for a high speed digital optocoupler for improving electrical noise immunity. The optional V_{CC} and Ground traces between the pin rows of the optocoupler help shield the output circuitry from electrical disturbances on the input pins, thus improving common-mode rejection.

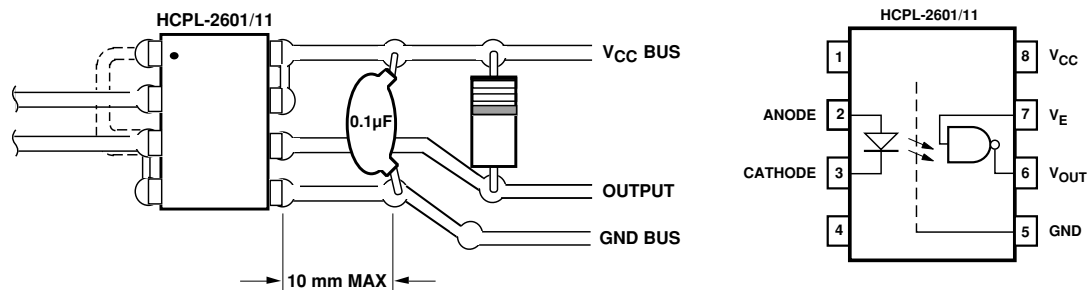

Figure 17. Optional Printed Circuit Board Layout for Improved Electrical Noise Immunity.

Digital Optoisolators: An Overview

Introduction

Avago Technologies offers a wide array of Optoisolators for noise rejection, ground loop current elimination, and high voltage isolation for digital data transmission and communication applications. The product offering includes low speed (100 kbit/s to 1 M bit/s) split Darlington or single transistor type optoisolators to high speed 25 M bit/s cascaded amplifier stage optoisolators with Schottky transistor or CMOS output stage.

Description

Figure 1 shows a Photodiode/Transistor Optoisolator where a PIN photodiode detector is coupled to a single transistor amplifier output stage (e.g. HCPL-4504). Compared to a typical phototransistor optoisolator, a PIN photodetector diode reduces the base-collector “Miller” capacitance and allows operability at a much higher speed.

Figure 2 shows a Split Darlington Output Stage, where an emitter-follower stage is added between a PIN photodiode and the output amplifier. This allows the optoisolator to be driven at a much lower input drive current, as low as 40 mA for the HCPL-4701/HCPL-4731 family or 0.5 mA for the 6N139 family. This allows much higher current transfer ratio (CTR) or current gain at the output, and TTL/CMOS gates can be easily driven.

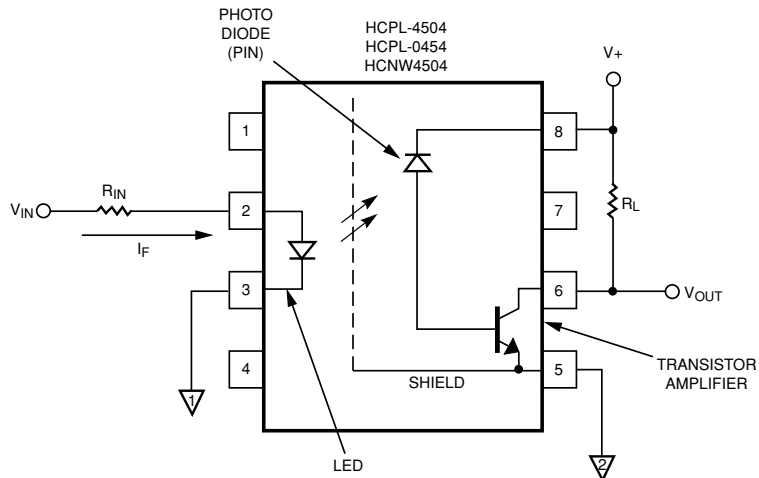

Figure 1. Photodiode/Transistor Optoisolator

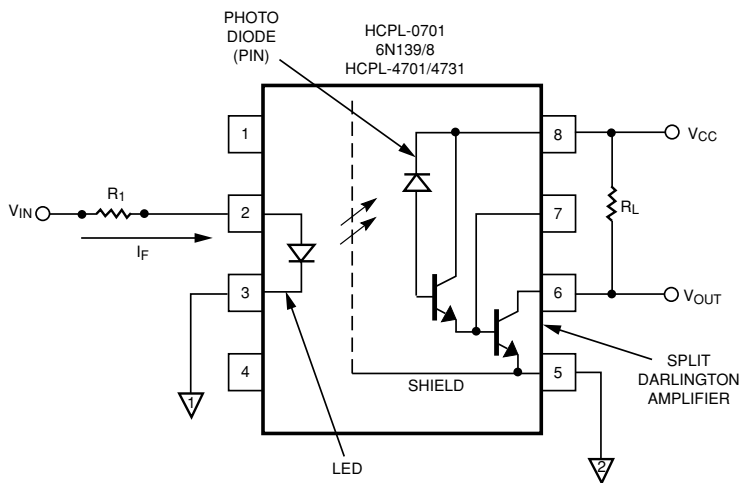

Figure 2. Split Darlington Transistor Optoisolator

DIGITAL INTERFACE

Figure 3 shows a photodiode cascaded amplifier, coupled to a Schottky transistor, open collector output stage. In order for an open collector output stage to function, a pull-up resistor is required at the output of the Optoisolator.

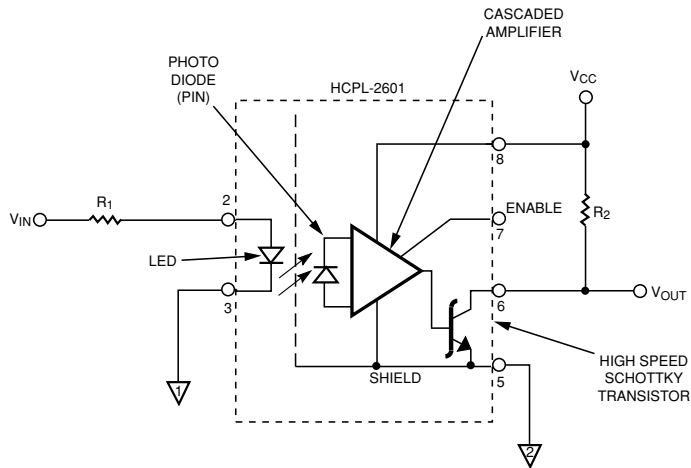

Figure 3. Cascaded Amplifier Optoisolator

Figure 4 shows a photodiode and cascaded amplifier, coupled to a totem pole output stage. This type of output stage eliminates the necessity of using a pull-up resistor at the output. The outputs can sink or source current allowing higher output power drive capability.

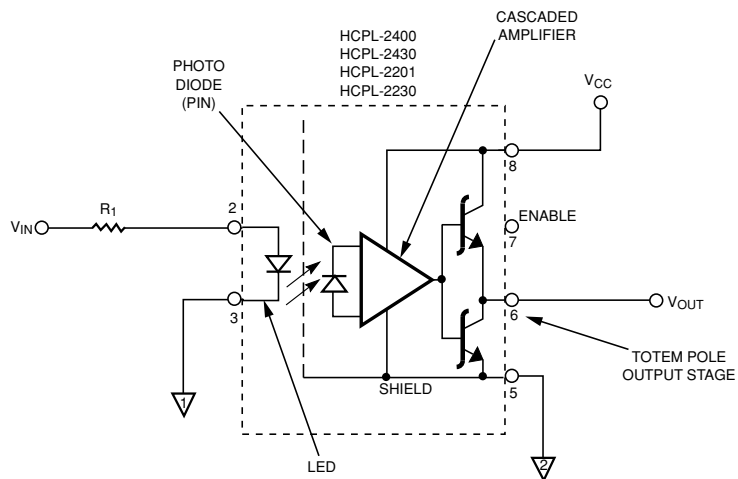
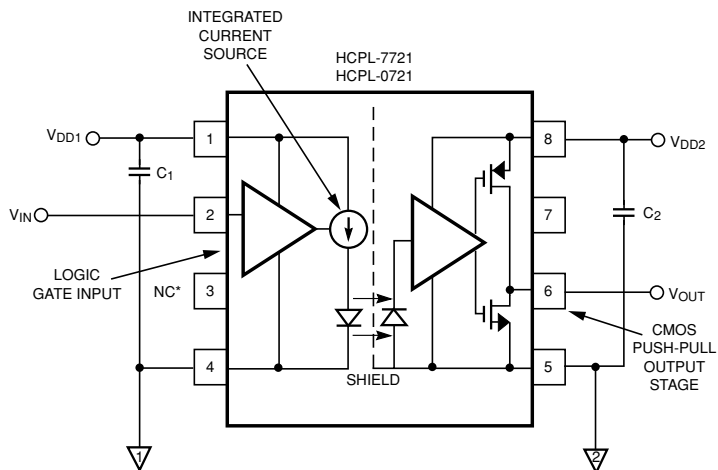

Figure 4. Totem Pole Output Optoisolator

Figure 5 shows a push-pull CMOS output stage. These types of optoisolators are designed to achieve highest speed performance (up to 25 M bit/s for HCPL-7721/7720). The amplifier stage presents very low input impedance to the photodiode, and does not become saturated, while allowing the signal to be amplified several folds through the amplifier stages, allowing operation at relatively low LED drive currents (2 to 5 mA).



*PIN 3 IS THE ANODE OF THE INTERNAL LED AND MUST BE LEFT UNCONNECTED FOR GUARANTEED DATA SHEET PERFORMANCE.
C₁, C₂ = 0.01 TO 0.1 μF

Figure 5. High Speed CMOS Optoisolators

TTL Interface with Series LED Drive

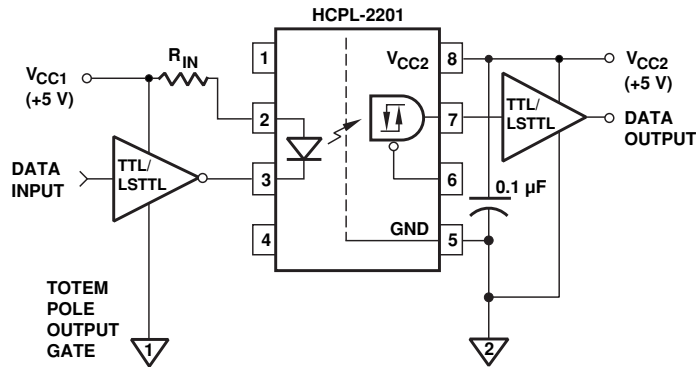

$$R_{IN} = \frac{V_{CC1} - V_F - V_{OL}}{I_F}$$

RECOMMENDED $R_{IN} = 1.1 \text{ k}\Omega$

Description

The circuit shown is an interface between two TTL gates using an active output (totem pole) optocoupler, the HCPL-2201. A series switching circuit drives the optocoupler LED. The designer chooses R_{IN} to agree with the equation shown in the schematic. The active output of the HCPL-2201 can be directly connected to a TTL gate, and no pull-up resistor is required. The HCPL-2201 can sink enough current to handle up to 16 LSTTL or 4 TTL loads.

Performance of Circuit

- Maximum optocoupler propagation delay: 300 ns (refer to alternative Avago parts for lower propagation delay times)
- Typical signaling rate: dc to 5 Mbd (refer to alternative Avago parts for higher speeds)
- Typical optocoupler LED drive current: 2 mA

Benefits

- No pull-up resistor required on the optocoupler output interface
- Low power dissipation on the optocoupler input circuit
- Up to 20 V supply voltage for the HCPL-2201

Alternative Avago Parts

- 1) HCPL-07XX, HCPL-2730/1, HCPL-4701, 6N138/9, CNW138/9 Low Input Current Optocouplers
- 2) HCPL-0201/11 Small-Outline Logic-Gate Optocoupler
- 3) HCPL-52XX Hermetically Sealed Logic-Gate Optocoupler
- 4) CNN2201/11 Widebody Logic-Gate Optocoupler
- 5) HCPL-2230/1 Dual-Channel Logic-Gate Optocoupler
- 6) HCPL-05XX, HCPL-2530/1, HCNW135/6, 6N135/6 High Speed Optocoupler
- 7) HCPL-250L/260L/270L, HCPL-050L/060L/070L 3.3 V Optocouplers

DIGITAL INTERFACE: Level Shifting/TTL Interface with Shunt LED Drive

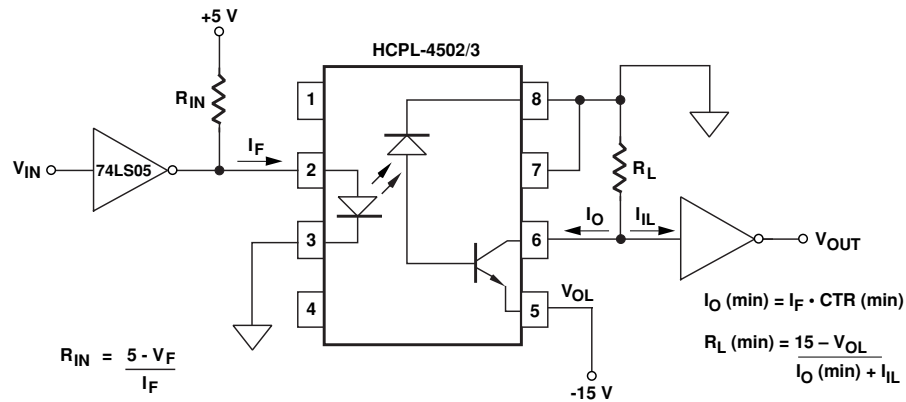

NOTE: FOR BEST CMR PERFORMANCE, CONNECT PIN 7 TO PIN 8.

Description

The above circuit shows how a 0 to 5 V logic signal can be level shifted to a -15 to 0 V signal. The circuit can safely be used for level shifting up to ± 800 V. The circuit uses an open collector output logic gate, the 74LS405, to drive the LED of the HCPL-4502/3 optocoupler. The HCPL-4502/3 also has an open-collector output. The designer chooses R_{IN} to agree with the equation shown in the schematic. This equation sets the value of the optocoupler LED forward current. The output of the HCPL-4502/3 requires a pull-up resistor, R_L . The current-transfer ratio (CTR) of the optocoupler determines the maximum amount of current the optocoupler output can sink while maintaining the output voltage (between pins 5 and 6) of 0.5 V or less.

Performance of Circuit

- Maximum optocoupler propagation delay: 2 μ s (refer to alternative Avago parts for lower propagation delays)
- Typical signaling rate: dc to 1 Mbd (refer to alternative Avago parts for higher speeds)
- Typical optocoupler LED drive current: 10 to 16 mA
- Maximum output supply voltage (pins 8-5): 30 V
- Minimum CMR: 15 kV/ μ s slew rate, 1500 V peak

Benefits

- Reduces transient immunity problems
- Convenient way of replacing pulse transformer for high-voltage level shifting

Alternative Avago Parts

- 1) HCPL-07XX, HCPL-2730/1, HCPL-4701, 6N138/9, HCNW138/9 Low Input Current Optocouplers
- 2) HCPL-55XX Hermetically Sealed High Speed Optocoupler
- 3) HCPL-0710 SO-8 High Speed CMOS Optocoupler
- 4) HCPL-250L/260L/270L, HCPL-050L/060L/070L 3.3V Optocouplers

DIGITAL INTERFACE

Low Power 8 MBd CMOS Interface

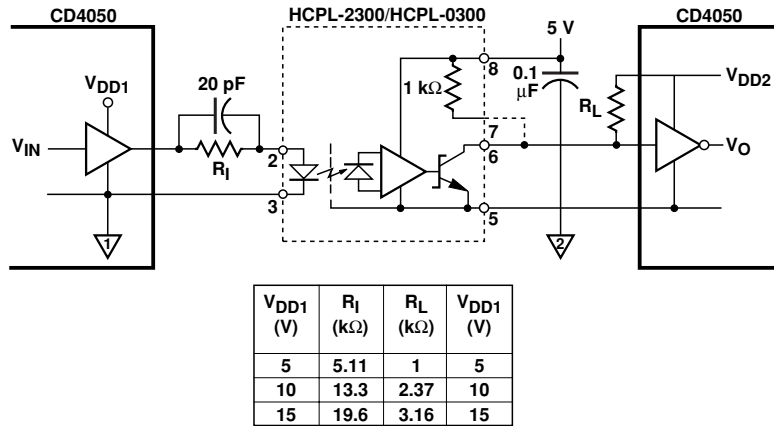

Description

A CMOS-to-CMOS interface is possible with Avago optocouplers. The above circuit shows an interface circuit for 8 MBd applications. Over the temperature range a CMOS CD4050 Hex Buffer can source about 0.7 mA (minimum), which is sufficient to drive the HCPL-2300/HCPL-0300 optocoupler. The 20 pF capacitor allows peaking currents to assist the LED turn on and off quickly.

Performance of Circuit

- Optocoupler LED current: 0.5 mA minimum
- Typical signaling rate: dc to 8 MBd

Benefits

- Low power consumption
- Simple interface

Alternative Avago Parts

- 1) HCPL-7721/7720/7710 High Speed CMOS Optocoupler
- 2) HCPL-0721//0720/0710 Small Outline High Speed CMOS Optocoupler

DIGITAL INTERFACE

25 MBd CMOS Interface

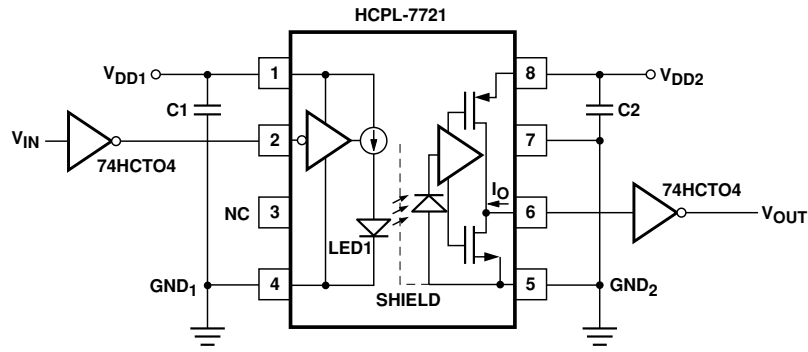

C1, C2 = 0.01 μ F TO 0.1 μ F

Description

Up to 25 MBd CMOS-to-CMOS interface is possible with the HCPL-7721 optocouplers. The above circuit requires only a bypass capacitor on each of the HCPL-7721 input-side and output-side power supply pins.

Performance of Circuit

- Typical logic low input power supply current for HCPL-7721: 1.5 mA
- Typical logic low input power supply current for HCPL-7721: 7 mA
- Typical HCPL-7721 signalling rate: dc to 25 MBd
- Typical HCPL-7721 pulse-width distortion: 3 ns
- Typical HCPL-7721 propagation delay: 20 ns

Benefits

- Lower power consumption
- Very simple interface

Alternative Avago Parts

- 1) HCPL-0721: SO8 package
- 2) HCPL-7720/0720: 25 MBd, 8 ns PWD CMOS interface optocoupler
- 3) HCPL-7710/0710: 25 MBd, 8 ns PWD CMOS interface optocoupler

DIGITAL INTERFACE

Low Power 100 kBd CMOS Interface

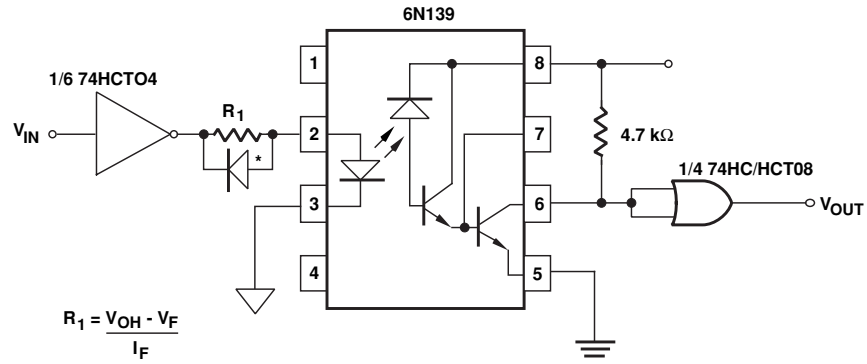

* USE ANY SIGNAL DIODE FOR CMR PROTECTION

Description

A CMOS-to-CMOS interface is possible with Avago optocouplers. The above circuit shows a cost-effective interface for 100 kBd applications. The 74HCT04 CMOS Hex Inverter that drives the optocoupler LED can source and sink up to 4 mA current. The 6N139 optocoupler requires only 0.5 mA LED current for operation. The signal diode across resistor R_1 protects against common-mode transient voltages and is optional. The output circuit uses a 74HCT08 so that the signal from V_{IN} to V_{OUT} is not inverted.

Performance of Circuit

- Minimum optocoupler LED turn-on current: 0.5 mA (The HCPL-4701 optocoupler requires only 40 μ A)
- Typical signaling rate: dc to 100 kBd
- Minimum optocoupler current transferratio: 400%

Benefits

- Low power consumption
- Simple interface

Alternative Avago Parts

- 1) HCPL-4701 Very Low Power High Gain Optocoupler
- 2) HCPL-2730/1 Dual Channel High Gain Optocoupler
- 3) HCPL-0731 Small Outline High Gain Optocoupler
- 4) HCPL-57XX, HCPL-67XX, 6N140 Hermetically Sealed High Gain Optocoupler
- 5) HCPL-270L 3.3V Optocoupler

DIGITAL INTERFACE

Isolated 3 V Logic Interface/Battery Operated Applications

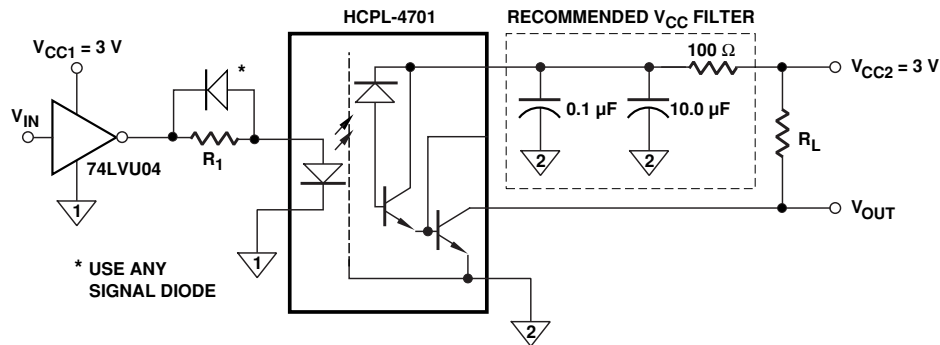

TYPICAL POWER DISSIPATION FOR 3 V APPLICATION
($V_{CC1}, V_{CC2} = 3.0\text{ V}, R_L = 11\text{ k}\Omega, R_1 = 43.8\text{ k}\Omega$)

V_{CC1} SIDE:		V_{CC2} SIDE:	
OPTOCOUPLER LED	50 μW	OPTOCOUPLER (V_O, V_{CC2})	85 μW
INPUT RESISTOR R_1	70 μW	PULL-UP RESISTOR R_L	790 μW
TOTAL V_{CC1} SIDE	120 μW	TOTAL V_{CC2} SIDE	875 μW

Description

The HCPL-4701 low-power optocoupler is used for 3 V-to-3 V Logic interface across an isolation barrier. Only 40 μA of LED current (I_F) is required to turn-on the optocoupler. Typical power for dissipation for just the optocoupler is 135 μW at $I_F = 40\text{ }\mu\text{A}$, and 965 μW at $I_F = 500\text{ }\mu\text{A}$.

Performance of Optocoupler

- Typical optocoupler current transfer ratio: 3500% at $I_F = 40\text{ }\mu\text{A}$
- Input current for optocoupler turn-on: 40 μA

Benefits

- Low power dissipation

Alternative Avago Parts

- 1) HCPL-4731 Dual Low Power Optocoupler
- 2) HCPL-070A SO-8 Low Power Optocoupler
- 3) HCPL-073A SO-8 Dual Channel Low Power Optocoupler
- 4) HCPL-050L/060L/070L, HCPL-250L/260L/270L 3.3V Optocouplers

Isolated RS-232C/E Interface

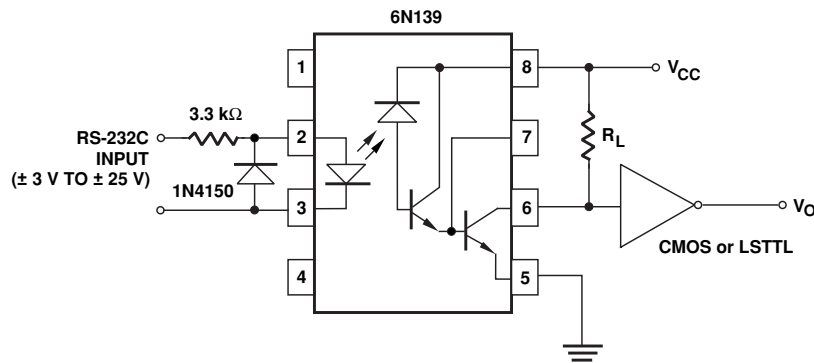

Description

The above schematic shows a very simple RS-232C data communication isolation interface using a 6N139 optocoupler. This circuit operates with an LED forward current of 0.5 mA when the input is at 3 V. The 1N4150 diode protects the LED during negative signal voltages. Since a low diode current is used to operate the 6N139, the twisted pair line can be up to 120 m. However, the data rate may have to be lowered to account for slower charging and discharging of the total line capacitance.

Performance of Circuit

- RS-232C link twisted pair cable length: up to 120 m for low data rates
- Typical optocoupler propagation delay: 20 μ s

Benefits

- Simple, low cost isolated interface
- Meets worldwide regulatory standards for isolation

Alternative Avago Parts

- 1) HCPL4701, 6N138/9, 4N45/6, HCPL-2730/1 High-Gain, Low Input Current Optocoupler
- 2) HCPL-0700/1, HCPL-0730/1, HCPL-M700/1 Small Outline High-Gain, Low Input Current Optocoupler
- 3) HCPL-270L/HCPL-070L 3.3V, 100 kBd Optocoupler

DATA COMMUNICATIONS

Isolated 3.3V RS-232 Interface

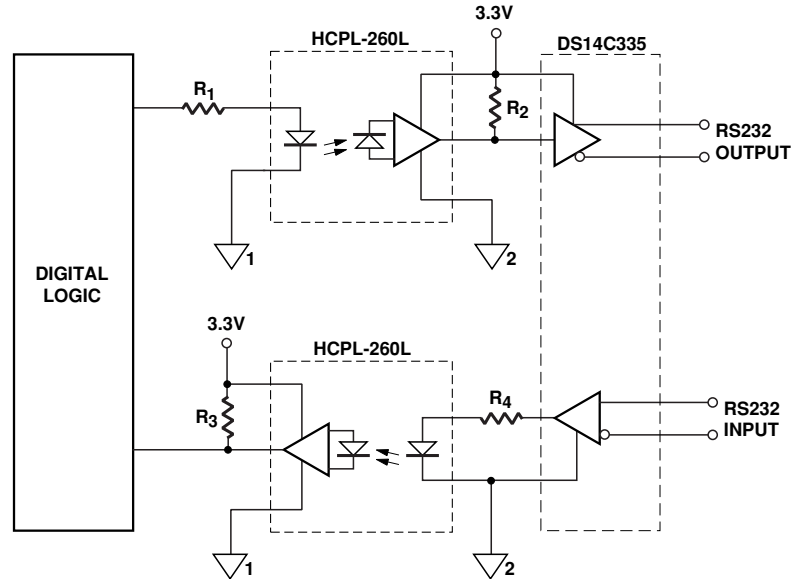

Description

The above isolated RS-232 circuit uses two high-speed 3.3V optocouplers that can switch up to 15 MBd signals. An isolated power supply is required to power the DS14C335 driver/receiver integrated circuit.

Performance of Circuit

- Typical signaling rate: up to 15 MBd
- Optocoupler LED drive current: 5 mA
- Typical Optocoupler Transient Rejection: 10,000 V/ μ s slew rate, 50 V peak

Alternative Avago Parts

- 1) HCPL-263L/HCPL-063L
Dual Low Power Optocoupler
- 2) HCPL-250L or HCPL-270L
for low data rate applications

Benefits

- Compact design with small outline optocouplers
- Prevents common-mode transients from interfering with the signal
- Low power dissipation

DATA COMMUNICATIONS

Isolated Device Net/CAN Communication Interface

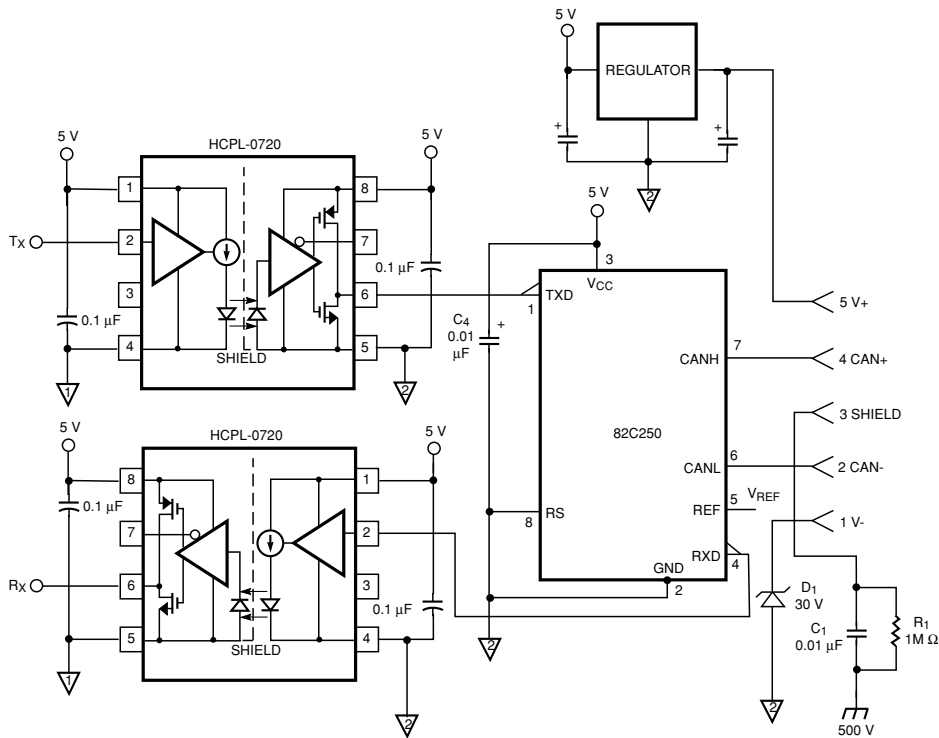

Description

DeviceNet, a factory floor communication network standard, sometimes may require connecting devices to be electrically isolated. The HCPL-0720 high speed CMOS optocoupler with a 40 ns maximum propagation delay time meets the DeviceNet physical layer specification.

Performance of Circuit

- Typical data rate (NRZ): Up to 12 Mbit/s
- Compatible with 5 V CMOS and TTL logic gates
- Minimum common mode transient immunity: 10 kV/μsec at $V_{CM} = 1000$ V

Benefits

- Direct interface to the optoisolator input and output (No external resistors necessary)
- Speed optimized for Profibus, RS-485, DeviceNet/CAN
- Small outline surface mount package offers space/footprint saving
- Performance guaranteed over industrial temperature range (0 to 85°C)

Alternative Avago Parts:

- 1) HCPL-7721/7720/7710 High Speed CMOS Optocoupler
- 2) HCPL-0721/0720/0710 SO-8 High Speed CMOS Optocoupler

ANALOG APPLICATIONS

Isolated 4-20 mA Analog Current Loop Transmitter/Receiver

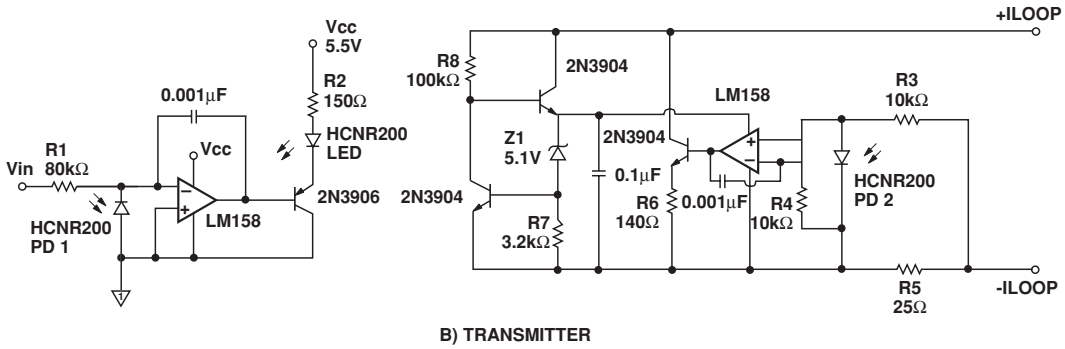
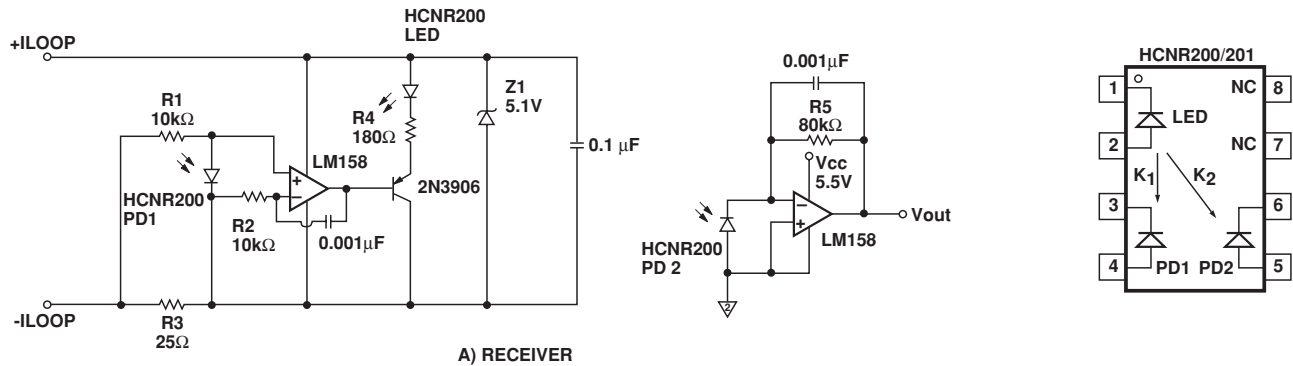

NOTE: The two OP-AMPS shown are two separate LM158, and NOT two channels in a single DUAL package; otherwise, the LOOP saide and input sied will not be properly isolated.

Description

The HCNR200/1 Analog Optocoupler isolates both the transmitter and receiver circuit from the 4 - 20 mA Analog Current Loop. One important feature of this circuit is that the loop side of the circuit is powered by the loop current. No isolated power supply is required.

Performance of Circuit

- Converts an analog voltage input to an analog current and vice versa
- HCNR200/1 nonlinearity: 0.1%
- HCNR201 gain tolerance: $\pm 5\%$

Benefits

- Low-cost simple circuit
- No isolated power supply needed on the 4 - 20 mA side of the circuit

Alternative Avago Parts

- 1) HCPL-4100 20 mA Current Loop Transmitter
- 2) HCPL-4200 20 mA Current Loop Receiver

DATA COMMUNICATIONS

Isolated 20 mA Current Loop Interface

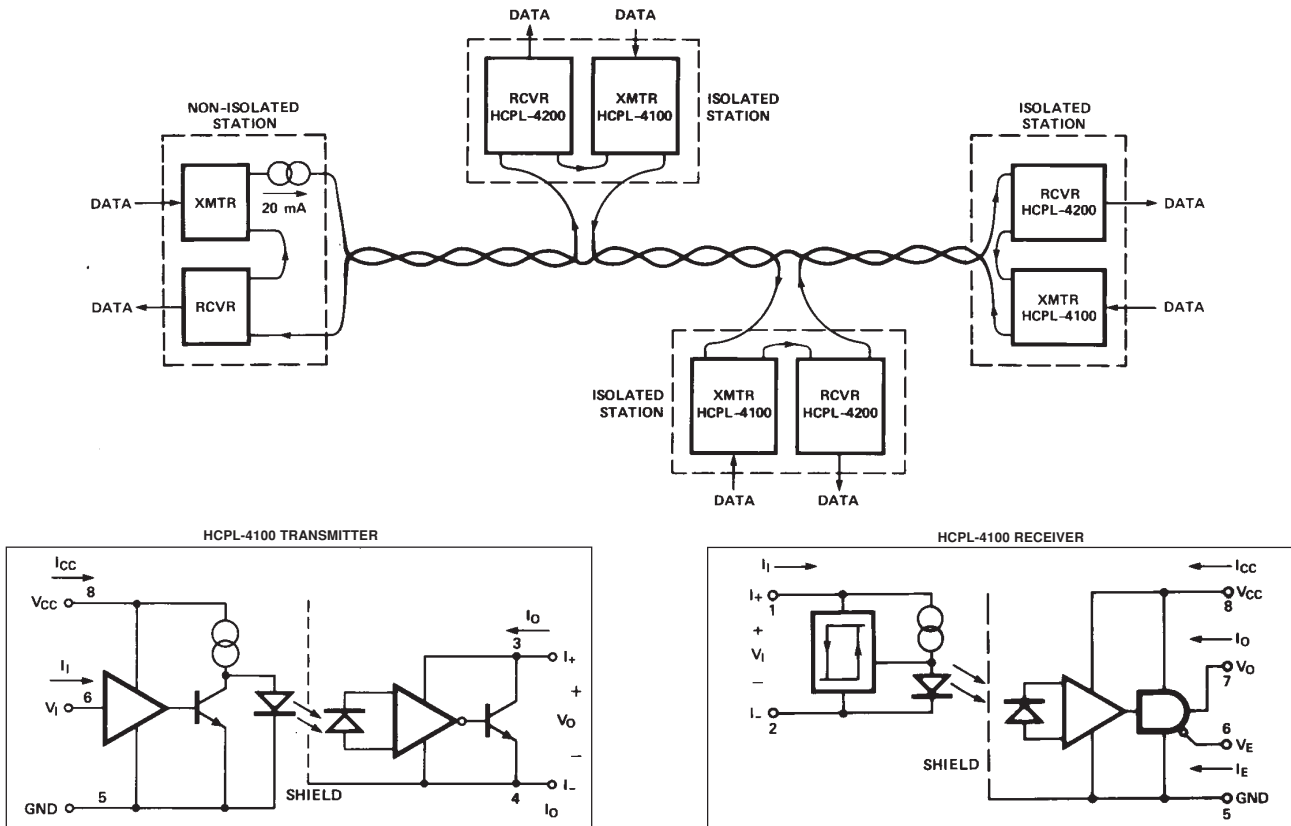

Description

The above half-duplex, point-to-point, multi-drop, 20 mA current loop configuration can alternately transmit bi-directional data over two wires. Only one current source is required. Each isolated station with an HCPL-4100 transmitter and HCPL-4200 receiver optocouplers provides excellent common-mode rejection.

Performance of Circuit

- 1 mA noise margin in the “space” state
- 8 mA noise margin in the “mark” state
- Typical signal rate and distance: 40 m at 100 kBd; over 200 m at 10 kBd

Benefits

- Maintains data integrity
- Simple data transmission system for industrial applications

DATA COMMUNICATIONS

Multidrop Line Receiver

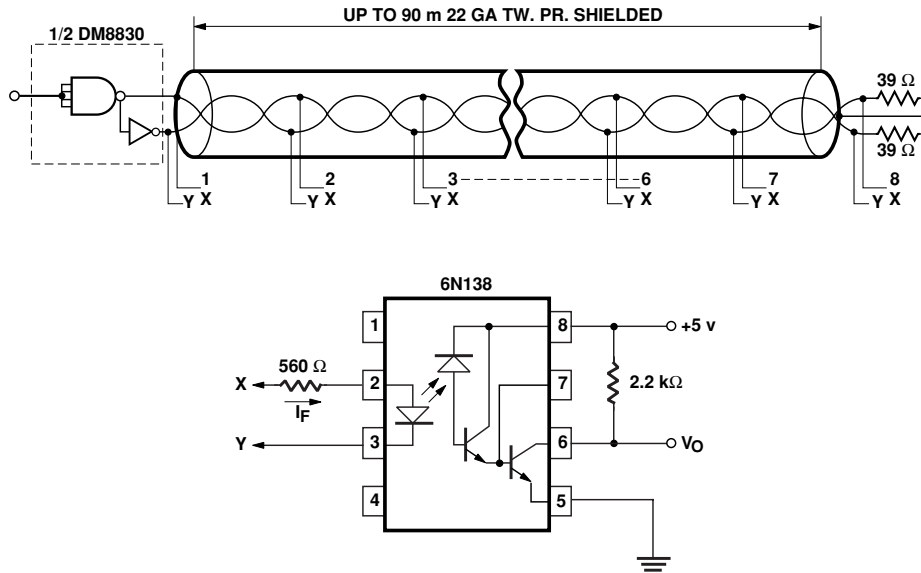

Description

The above differentially driven circuit can use up to eight 6N138 optocouplers at various receivers along the 90 m line. All stations are isolated. The first station would draw approximately 2.7 mA current, and the last station 1.8 mA of LED drive current. The output grounds of the optocoupler may be electrically separate.

Performance of Circuit

- Typical signaling rate: 18 kBd (faster signaling rates can be obtained with HCNW139 and 6N139)
- Typical optocoupler propagation delay time: $t_{PHL} = 2 \mu s$; $t_{PLH} = 20 \mu s$
- Up to 90 m distance

Benefits

- Simple, low-cost, multidrop circuit for low signaling rates

Alternative Avago Parts

- 1) HCPL-0700/01/30/31, HCPL-M700/1, HCNW138/9, and HCPL-2730/31 Low-Input Current Optocouplers
- 2) HCPL-57XX, HCPL-67XX, and 6N140 Hermetically Sealed Low-Input Current Optocouplers
- 3) HCPL-2300 High Speed, Low Input Current Optocoupler

DATA COMMUNICATIONS

Isolated Balanced Line Receiver - Circuit No. 1

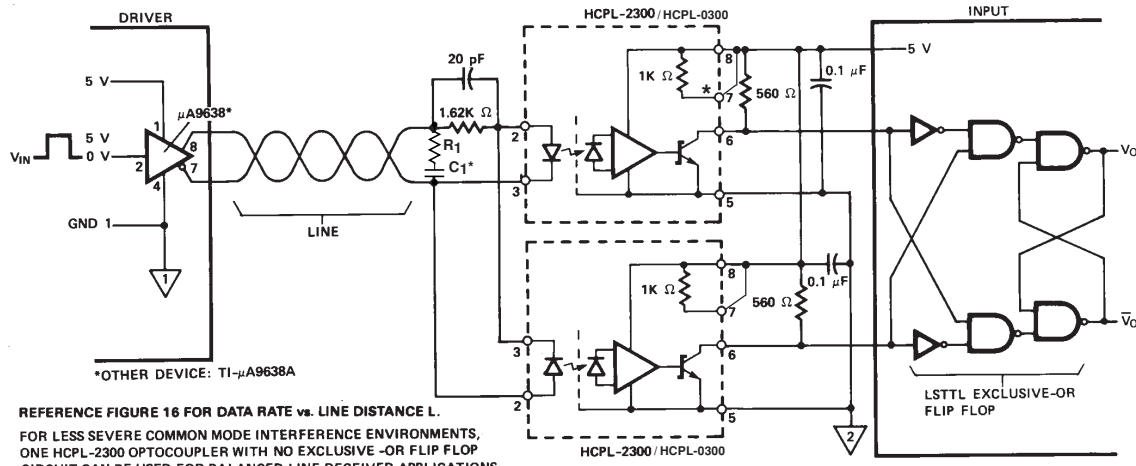

REFERENCE FIGURE 16 FOR DATA RATE vs. LINE DISTANCE L.
 FOR LESS SEVERE COMMON MODE INTERFERENCE ENVIRONMENTS,
 ONE HCPL-2300 OPTOCOUPLER WITH NO EXCLUSIVE -OR FLIP FLOP
 CIRCUIT CAN BE USED FOR BALANCED LINE RECEIVER APPLICATIONS.
 $V_O = V_{IN}$.

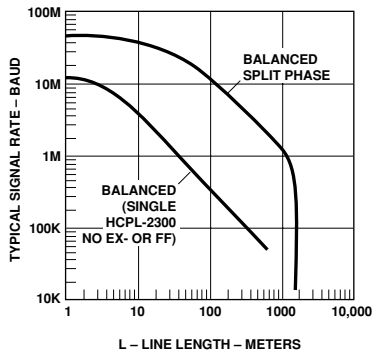

10% PULSE WIDTH DISTORTION
 22 AWG UNSHIELDED TWISTED
 PAIR WIRE CABLE (DEARBORN
 NO. 862205)
 $T_A = 25^\circ C$

Description

A balanced RS-422 line driver differentially drives a twisted pair line. Two HCPL-2300s provide balanced signal direction for this line. The thresholds of the HCPL-2300 will be nearly equal, providing symmetrical signal detection level. Since the propagation delays of the two optocouplers are similar, the pulse-width distortion for this scheme will be quite low for considerable line lengths. The Exclusive-Or flip-flop circuit at the optocoupler output increases CMR protection to an extremely high level and balances the propagation delays. For less demanding noise environments, only one HCPL-2300 with no EX-OR flip-flop may be used. The maximum data rate, however, will be somewhat lower.

Performance of Circuit

- Signaling rate: > 10 Mb/d at 100 m line length
- Common mode rejection: > 15,000 V/μs

Benefits

- Very high common-mode transient rejection
- Data transmission for up to 1 km distance

Alternative Avago Parts

HCPL-2602/12 High CMR Line Receiver

DATA COMMUNICATIONS

Isolated Balanced Line Receiver - Circuit No. 2

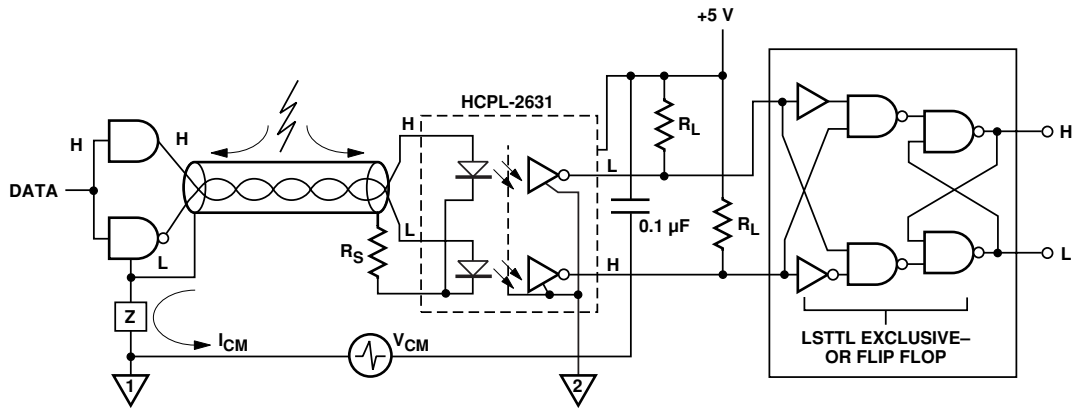

Description

This is a differential receiver using a dual-channel HCPL-2630 Optocoupler. The receiver circuit can handle data up to 10 Mbd for short line lengths. The capacitance of the twisted-pair wire introduces a propagation delay and, as a result, the data rate decreases with increasing line length. At the optocoupler output, an optional Exclusive-Or circuit can be used to increase CMR and to balance the propagation delays.

Performance of Circuit

- Signaling rate: up to 10 MBd
- Optocoupler common mode rejection: 10,000 V/μs

Benefits

- Dual channel optocoupler reduces boardspace
- Balanced circuit increases CMR performance thereby eliminating or reducing transient interference

Alternative Avago Parts

- 1) HCPL-0631 Small Outline, Dual-Channel, High Speed Optocoupler
- 2) HCPL-4661 High-CMR, Dual-Channel Optocoupler
- 3) HCPL-56XX Hermetically Sealed High Speed Optocouplers

DATA COMMUNICATIONS

Isolated Tri-State Line Driver

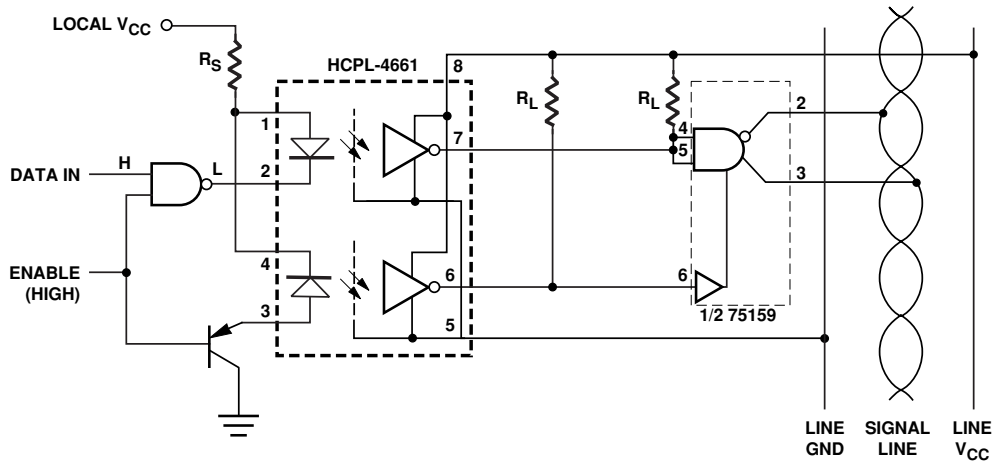

Description

The above circuit converts a single-ended signal to a split-phase signal with a 75159 Tri-State Line Driver and dual-channel HCPL-4661 High CMR Optocoupler. When Input Enable goes low, the lower channel of the optocoupler operates the “strobe” input of the 75159 to make both outputs open.

Performance of Circuit

- Optocoupler signaling rate: up to 10 MBd
- Optocoupler CMR: 15,000 V/ μ s at 1000 V peak (typical)

Benefits

- Higher data rate than a current source pull-up
- High CMR performance reduces or eliminates transient noise

Alternative Avago Parts

- 1) HCPL-063N SO-8 High CMR Dual Channel Optocoupler
- 2) HCPL-2631 Dual Channel High Speed Optocoupler
- 3) HCPL-0631 Small Outline, Dual Channel Optocoupler
- 4) HCPL-56XX Hermetically Sealed High Speed Optocouplers
- 5) HCPL-053L/063L/073L, HCPL-253L/263L/273L 3.3V Optocouplers

DATA COMMUNICATIONS

Isolated Unbalanced Line Receiver

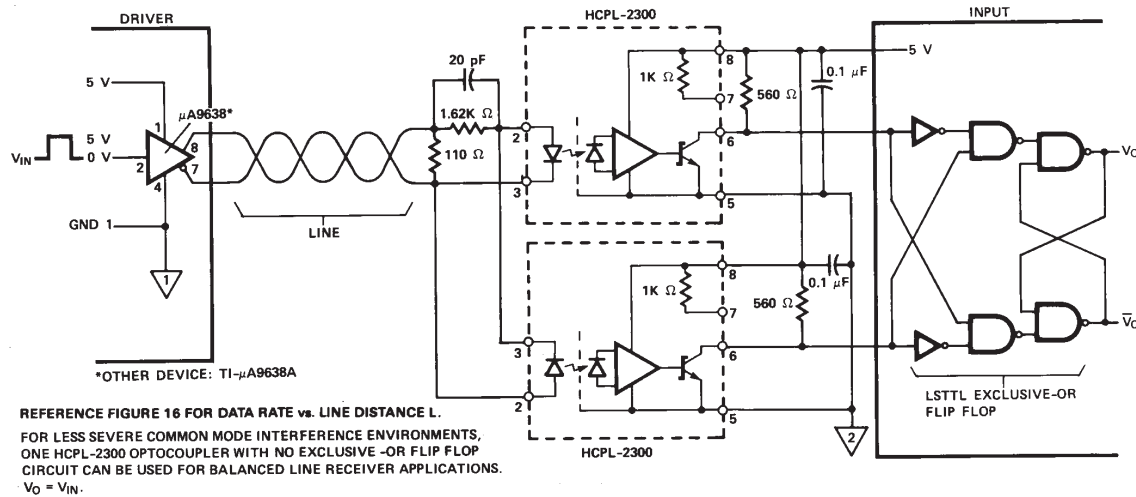

Description

The above illustration is an unbalanced line receiver using the integrated voltage-clamp input optocoupler, HCPL-2602. The circuit is unbalanced because the termination impedance is different for both “ends” of the differential signal received by the HCPL-2602. TTL data is converted to a differential signal via the differential line driver 9614, and transmitted over twisted-pair wire. The Schottky diode helps to improve the turn-on and turn-off delays.

Performance of Circuit

- Signaling rate: up to 2 MBd at 90 m (up to 10 MBd with polarity non-reversing driver)
- Optocoupler common-mode transient rejection: 10,000 V/μs (typical)

Benefits

- Integrated line termination and voltage clamping saves board space
- Differential driver and optical isolated receiver reduce or eliminate transient noise interference

Alternative Avago Parts

- 1) HCPL-2611 High CMR, High Speed Optocoupler
- 2) HCPL-0601/0631 Small Outline, High Speed Optocoupler
- 3) HCNW2601 Widebody, High Speed Optocoupler

DATA COMMUNICATIONS

PROFIBUS/RS-422 1.5 MB/s

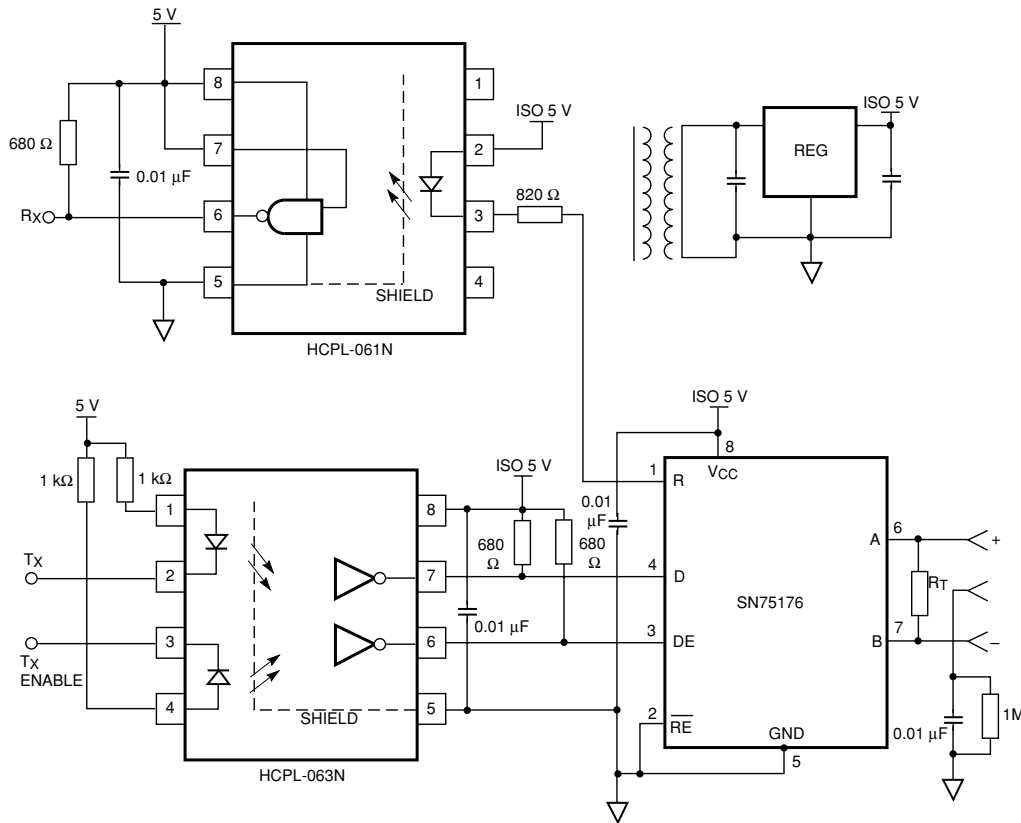

Description

Profibus (Process Fieldbus) is essentially a twisted wire pair serial link very similar to RS-485 or 422. Profibus speed standard is either lower speed (1.5 MBd) or higher speed (12 MBd). In this application circuit the Profibus is shown to be isolated with HCPL-061N (single channel optoisolator) and HCPL-063N (dual channel optoisolator).

Performance of Circuit

- Typical data rate (NRZ): Up to 10 Mbit/s
- Multipoint bus transmission line application
- Open collector output, HCMOS/TTL compatible
- Maximum propagation delay of optoisolator: 0.1 μsec
- Minimum common mode transient immunity: 15 kV/μsec at $V_{CM} = 1000$ V
- Low minimum drive current: 3 mA

Benefits

- Low input drive current maximizes LED lifetime/reliability
- Speed optimized for Profibus (1.5 MBd) and RS-422 (10 MBd)
- Performance guaranteed over temperature (-40 to 85°C)

Alternative Avago Parts

- 1) HCPL-0261 Single Channel Optocoupler
- 2) HCPL-56XX High CMR, Hermetically Sealed Optocoupler
- 3) HCPL-050L/060L/070L, HCPL-250L/260L/270L 3.3V Optocouplers
- 4) HCPL-053L/063L/073L, HCPL-253L/263L/273L 3.3V Optocouplers

DATA COMMUNICATIONS

Isolated PROFIBUS/RS-485

12 MB/s Communication Application

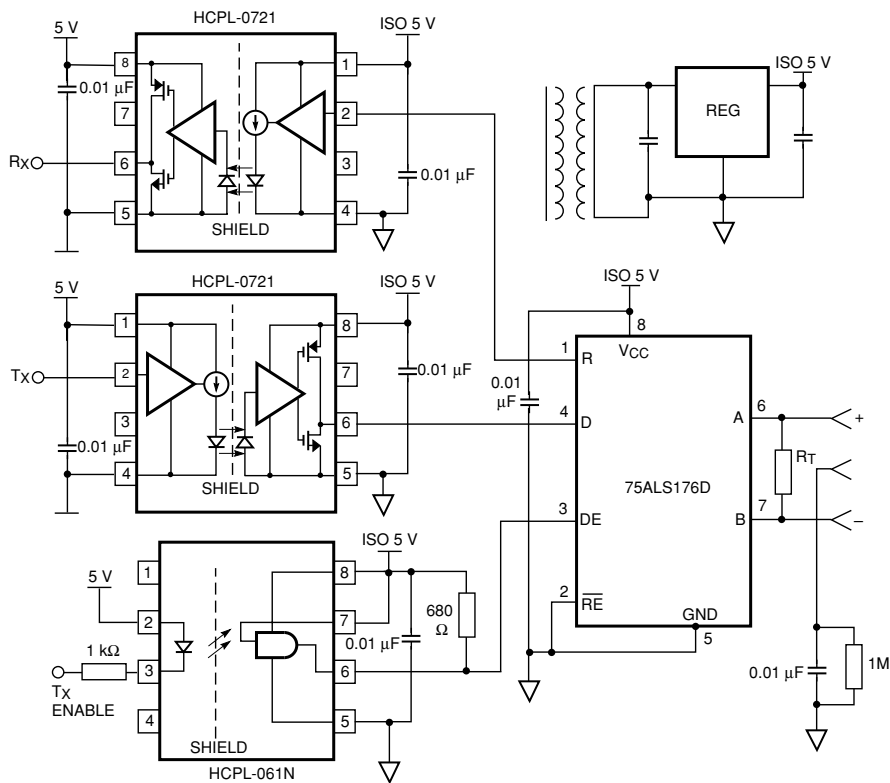

Description

Profibus (Process Fieldbus) is essentially a twisted wire pair serial link very similar to RS-485 or 422. Profibus speed standard is either lower speed (1.5 MBd) or higher speed (12 MBd). In this isolated multipoint transmission application circuit, two different optoisolators are utilized (HCPL-0721 and HCPL-061N).

Performance of Circuit

- Typical data rate (NRZ): Up to 12 Mbit/s
- Multipoint bus transmission line application
- Compatible with 5 V CMOS and TTL logic gates
- Maximum propagation delay of optoisolator: 0.04 μ sec
- Minimum common mode transient immunity: 10 kV/ μ sec at $V_{CM} = 1000$ V

Benefits

- Low input drive current maximizes LED lifetime/reliability
- Speed optimized for Profibus and RS-485
- Performance guaranteed over temperature (-40 to 85°C)

Telephone Ring Detection

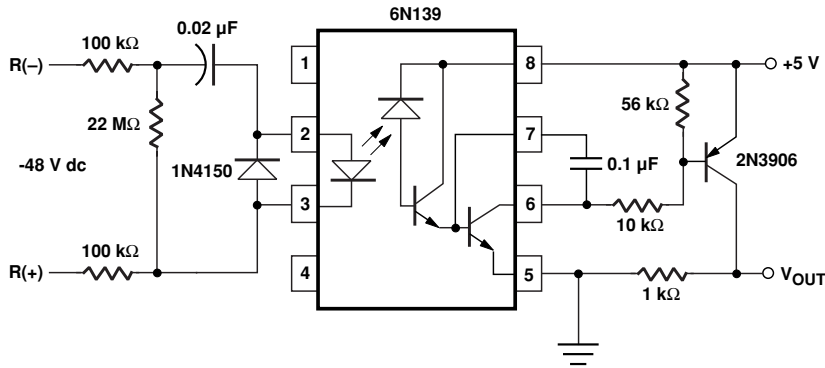

Description

The 6N136 Low-Input Current Optocoupler is used to detect standard telephone ring signals. At the optocoupler output, a 0.1 μF base-collector capacitor provides a large enough Miller-capacitance so that a low-frequency ring signal (20 to 60 Hz) causes the output to remain low when ringing occurs.

Performance of Circuit

- Can detect 20 to 60 Hz, 30 to 80 V_{RMS} telephone ring signals

Benefits

- Simple and inexpensive circuit for ring signal detection
- Meets worldwide regulatory isolation standards

References

6N139 Low-Input Current Optocoupler Technical Data

Alternative Avago Parts

- 1) HCPL-0701 Small Outline, Low-Input Current Optocoupler
- 2) HCPL-3700/60 Threshold Sensing Optocoupler
- 3) HCNW139 Low-Input Current Optocoupler

TELECOMMUNICATIONS APPLICATIONS

ISDN Interface

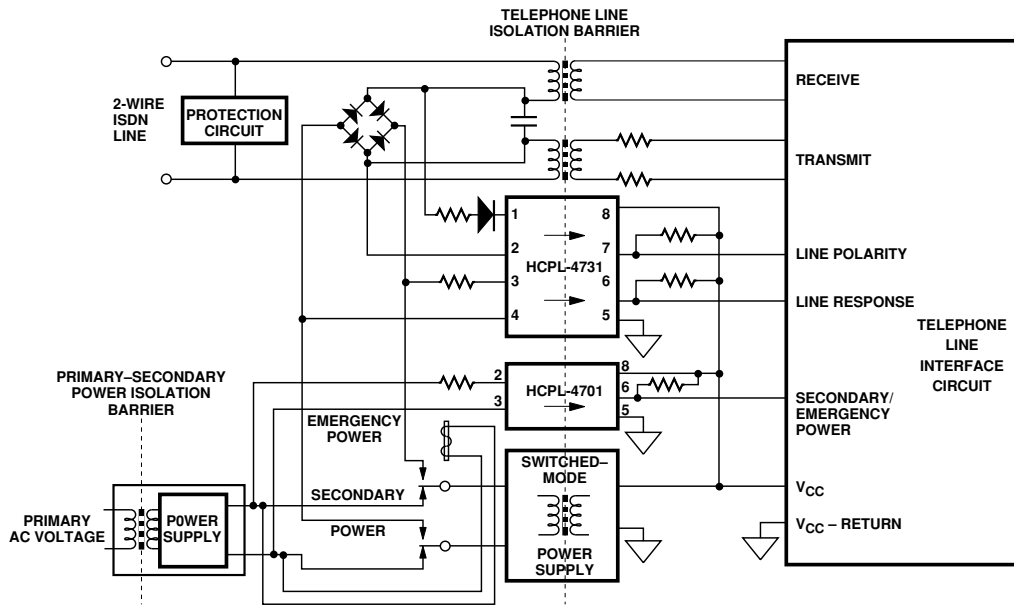

Description

The HCPL-4701 Low Power Optocoupler is suitable for standard telephone line interface functions such as: ring detection, line polarity, and power on/off detection. Integrated Services Digital Network (ISDN) applications severely restrict the input power that an optocoupler interface circuit can use, which makes the HCPL-4701 an ideal choice. Similarly, HCPL-270L, 3.3V optocoupler could be used which is compatible with JEDEC low voltage specifications.

Performance of Optocoupler

- Input current for turn-on: 40 μ A
- Typical total power dissipation with $I_F = 40 \mu$ A: < 3 mW
- Typical propagation delay: 65 μ s

Benefits

- Low power dissipation
- Compatible with 3 V Logic

References

- HCPL-4701 Lower Power Optocoupler Technical Data
- HCPL-270L 3.3V Optocoupler Technical Data

Analog Isolation Applications with Linear Optocouplers

Introduction

Optoisolators transfer analog and digital signals from one circuit section or module to another in the presence of a large potential difference or induced electrical noise between the ground or common points of these modules. Examples of analog isolation applications are interfaces to: A/D converters, sensing circuits such as thermocouples and transducers, patient monitoring equipment, motor speed and position measurement circuits, audio and video amplifiers, and power supply feedback.

Basic Building Blocks for Analog Isolation

Avago Technologies' HCNR200/1 and HCPL4562 constitute basic optical coupling building blocks for high linearity isolation applications. Figures 1 and 2 show the respective optical coupling mechanisms for these two optoisolators. Both these isolators use high-performance AlGaAs LEDs and photodiode combinations with higher speed and linearity compared to conventional optoisolators. The HCNR200/1 LED illuminates two closely matched photodiodes, one on the input side, and another on the output side. With a suitable applications circuit for the HCNR200/1, the nonlinearity and drift characteristics of the LED can be virtually eliminated. The output photodiode produces a photocurrent that is linearly related to the light output of the LED. The close matching of the photodiodes and advanced design of the package ensure the high linearity and stable gain characteristics of the optoisolator.

The HCNR200/1 optoisolator can be used as a basic analog isolation building block for a wide variety of applications that require good stability, linearity, bandwidth and low cost. The HCNR200/1 is very flexible and, by appropriate design of the application circuit, is capable of operating in many different modes, including unipolar, bipolar, ac/dc, inverting and non-inverting.

The HCPL-4562 and HCNW4562 are recommended for very high bandwidth (up to 15 MHz) AC analog designs. If the output transistor is biased in the active region, the current transfer ratio relationship for the HCPL-4562 can be represented as:

$$I_C = K (I_F / I_{FQ})^n$$

where I_C is the collector current; I_F is the LED input current, I_{FQ} is LED input current at which K is measured; K is the collector current when $I_F = I_{FQ}$; and n is the slope of I_C vs. I_F on logarithmic scale.

The exponent n varies with I_F , but over some limited range of I_F , n can be regarded as a constant. For ac-signal applications, the HCPL-4562 can be biased at an appropriate quiescent current where the ratio of the incremental photodiode current to incremental LED current is nearly constant. Figure 3 shows the linearity characteristics of the HCPL-4562.

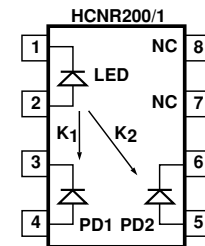

Figure 1. HCNR-200/1 High Linearity Analog Isolator

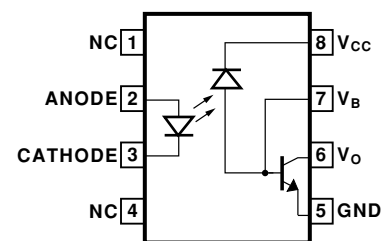

Figure 2. HCPL-4562 High Bandwidth Analog Isolator

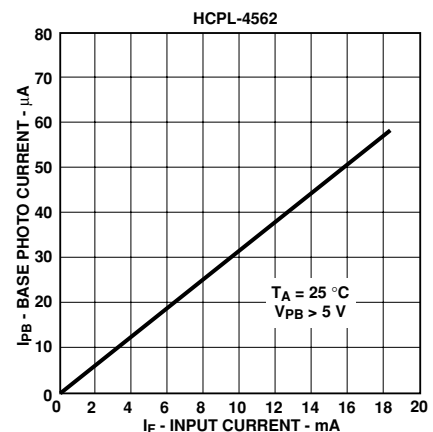
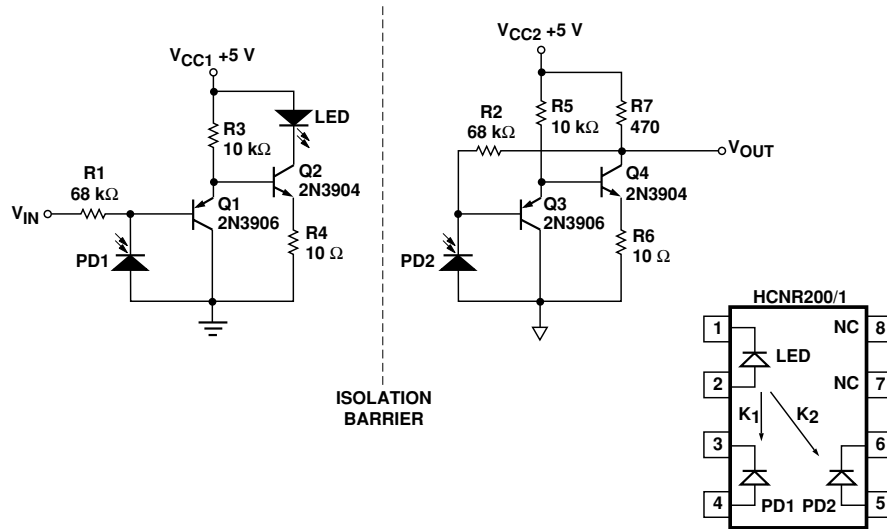

Figure 3. HCPL-4562 Base Photo Current vs. Input Current

ANALOG APPLICATIONS

High Speed Isolation Amplifier



Description

This is a high-speed, low-cost isolation amplifier for use in the feedback path of switch-mode power supplies or motor speed and position measurement. This circuit can be used in applications where high bandwidth, low-cost, and stable gain are required, but where accuracy is not critical.

Performance of Optocoupler

- 1.5 MHz bandwidth
- Stable gain
- Low-cost support circuit
- Circuit couples only positive voltage signals

Benefits

- Low cost solution for coupling positive voltage analog signals
- Simple way for sending power supply voltage feedback signal across isolation barrier

References

HCNR200/1 Technical Data

Alternative Avago Parts

- 1) HCPL-7800A, HCPL-7800, HCPL-7840 Isolation Amplifier
- 2) HCPL-4562 Wideband Analog/Video Optocoupler
- 3) HCPL-785X Hermetically Sealed Isolation Amplifier

ANALOG APPLICATIONS

Precision Isolation Amplifier for Unipolar Signals

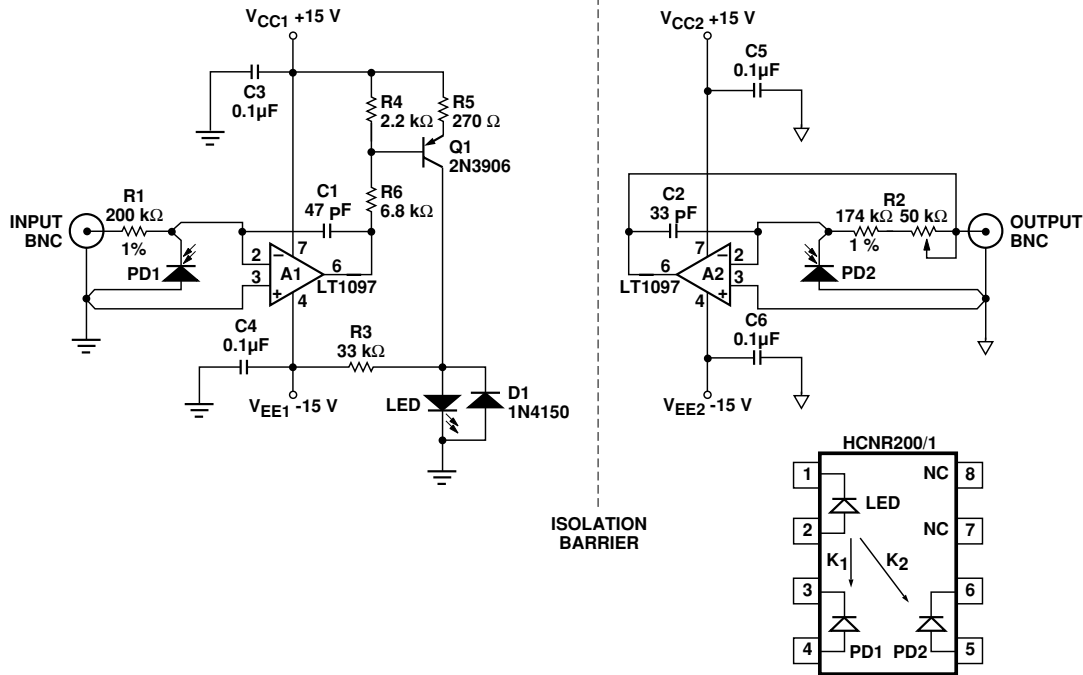

Description

This circuit uses the HCNR200/1 High-Linearity Analog Optocoupler to achieve high accuracy and wide dynamic range at a reasonable cost. This is accomplished by using low-cost, precision op-amps with very low input bias currents and offset voltages. The circuit couples only positive voltage analog signals.

Performance of Circuit

- DC to 10 kHz bandwidth
- Stable gain
- 0.1% nonlinearity
- 1 mV to 10 V input/output voltage range

Benefits

- Low-cost, high-accuracy solution for coupling analog signals
- Easy availability of support circuit components
- No offset adjustment is required

References

HCNR200/1 Technical Data

Alternative Avago Parts

- 1) HCPL-7800A, HCPL-7800, HCPL-7840 Isolation Amplifier
- 2) HCPL-4562 Wideband Analog/Video Optocoupler
- 3) HCPL-785X Hermetically Sealed Isolation Amplifier

ANALOG APPLICATIONS

Isolation Amplifier for Bipolar Signals - Circuit No. 1

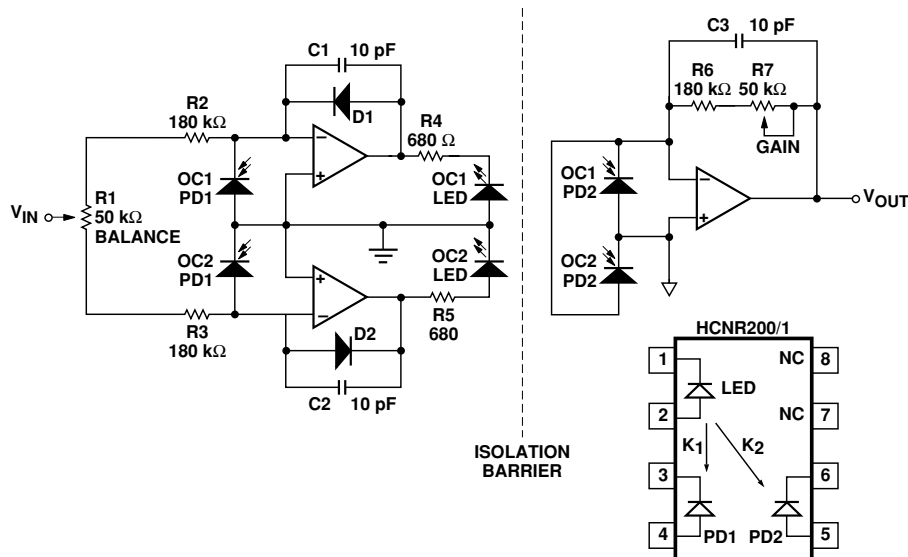

Description

This circuit shows how the HCNR200 High Linearity Optocoupler can be used for transmitting bipolar analog signals across an isolation boundary. This circuit uses two optocouplers: OC1 and OC2; OC1 handles the positive portions of the input signal and OC2 handles the negative portions. Diodes D₁ and D₂ help reduce cross-over distortion by keeping both amplifiers active during both positive and negative portions of the input signal.

Performance of Circuit

- 0.01% nonlinearity
- Bandwidth: dc to 100 Hz
- Low transfer gain variation: $\pm 5\%$ (K3 of HCNR201)

Benefits

- Low drift
- Low crossover distortion within the dc to 100 Hz frequency band
- Good linearity
- Very low offset

References

HCNR200/1 Technical Data

Alternative Avago Parts

- 1) HCPL-7800A, HCPL-7800, HCPL-7840 Isolation Amplifier
- 2) HCPL-785X Hermetically Sealed Isolation Amplifier

ANALOG APPLICATIONS

Isolation Amplifier for Bipolar Signals - Circuit No. 2

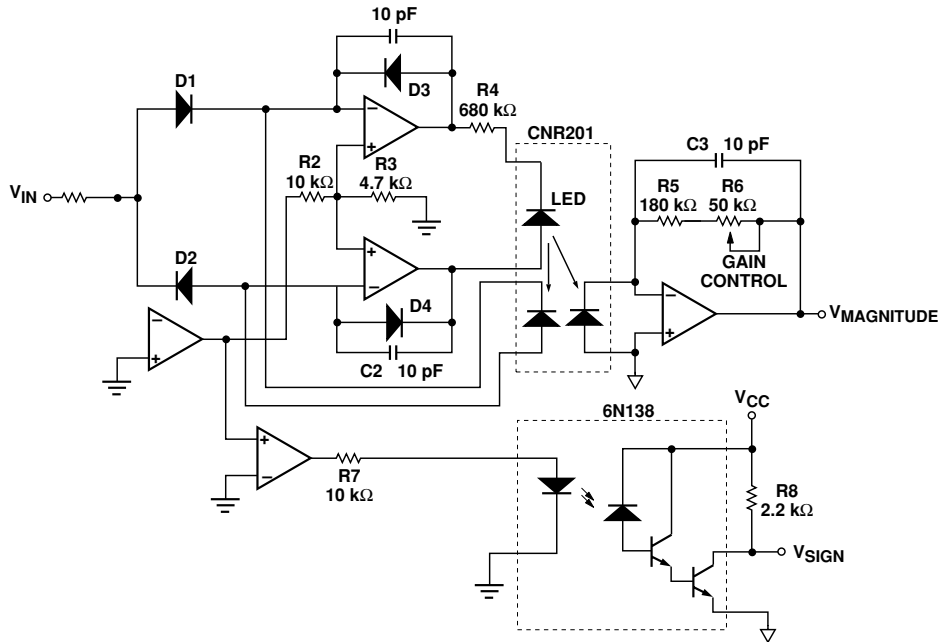

Description

This circuit shows how bipolar analog signals can be transmitted across an isolation boundary by using just one HCNR200 optocoupler. This circuit provides an easy interface to A/D converters with two output signals: an analog signal proportional to the magnitude of the input signal, and a digital signal corresponding to the Sign of the input signal. The HCNW138 optocoupler, which couples the Sign signal, can be substituted with a faster optocoupler in case the Sign changes faster than 50 kHz.

Performance of Optocoupler

- 0.01% nonlinearity
- Wide bandwidth: dc to 1 MHz
- Low transfer gain variation: $\pm 5\%$ (K3 of HCNR201)

Benefits

- Low drift
- Very low offset

References

HCNR200/1 Technical Data

Alternative Avago Parts

- 1) HCPL-7800A, HCPL-7800, HCPL-7840 Isolation Amplifier
- 2) HCNW2601 High Speed Digital Optocoupler (for the Sign signal)
- 3) HCPL-785X Hermetically Sealed Isolation Amplifier

ANALOG APPLICATIONS

AC-Coupled Isolation Amplifier

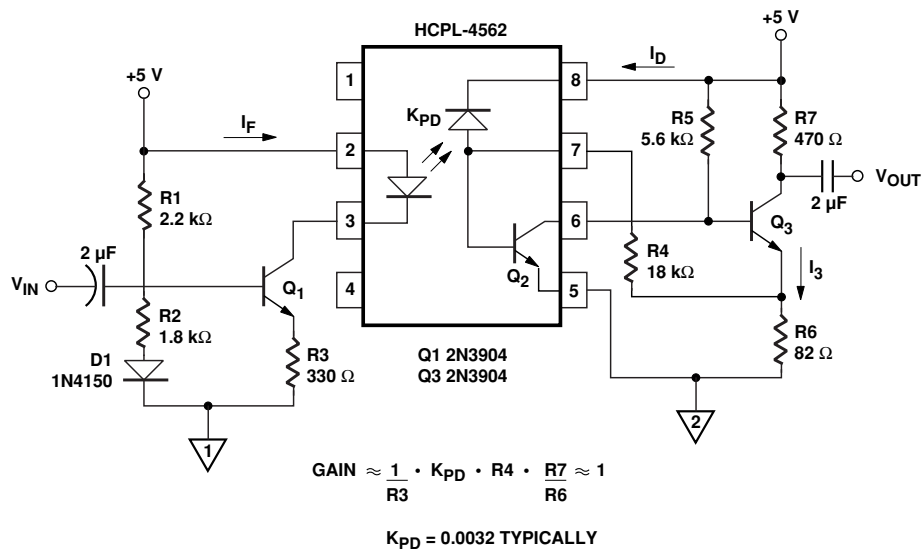

Description

This circuit with the HCPL-4562 Wideband Analog/Video Optocoupler functions as an ac-coupled isolation amplifier that can be used for coupling audio or video signals. The input circuit biases the optocoupler LED at a quiescent current of about 6 mA, determined primarily by resistors R_1 , R_2 , and R_3 . Diode D_1 helps to stabilize the operating point over the operating temperature range. An ac-coupled signal will modulate the collector current of transistor Q_1 and the optocoupler LED. The output circuit consists of a simple transresistance (current-in, voltage-out) amplifier followed by a common-emitter amplifier stage.

Performance of Circuit

- Typical bandwidth: 13 MHz
- Nominal gain of circuit: 1
- Isolation-mode rejection: 46 dB at 1 kHz
- Overall nonlinearity: 0.5%
- Optocoupler input current range: 4 mA-8 mA

Benefits

- Simple solution for coupling audio and video signals

References

- 1) HCPL-4562 Wideband Analog/Video Optocoupler Technical Data
- 2) Application Note 951-2, "Linear Applications of Optocouplers"

Alternative Avago Parts

- 1) HCPL-2502, 6N135, 6N136 High Speed Transistor Output Optocouplers
- 2) HCNW4562 Widebody Wideband Analog/Video Optocoupler
- 3) HCPL-55XX, 4N55, HCPL-6530/1 Hermetically Sealed High Speed Optocoupler
- 4) HCPL-05XX Small-Outline High Speed Optocoupler

Isolated Video Interface

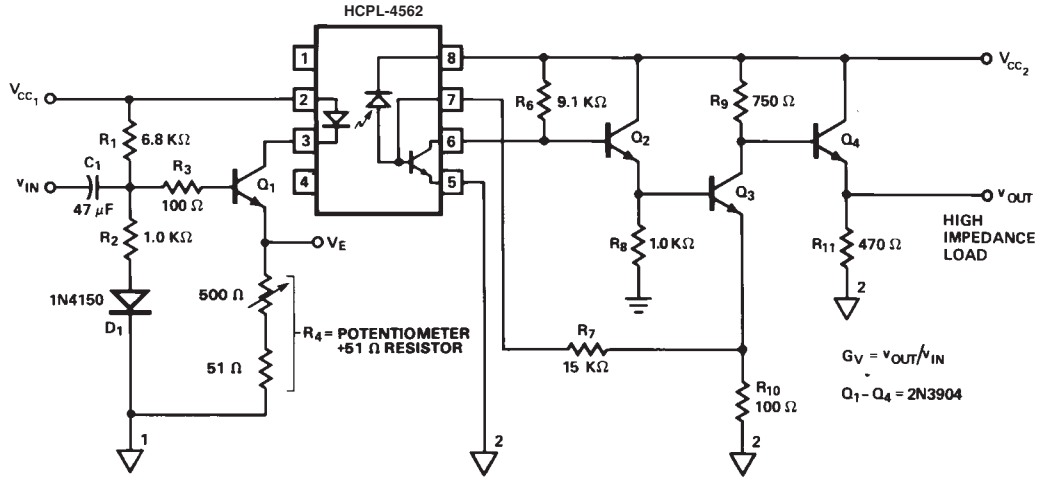

Description

This circuit, with the HCPL-4562 Wideband Analog/Video Optocoupler, is optimized for video signal coupling. The peaked response of the detector circuit helps extend the frequency range over which the gain is relatively constant. The number of gain stages, the overall circuit topology, and the dc bias points are all chosen to maximize the bandwidth.

Performance of Circuit

- Typical bandwidth: 15 MHz
- Typical Gain variation: -1.1 dB at 5 MHz with reference at 0.1 MHz
- Isolation Mode Rejection: 122 dB at 120 Hz

Benefits

- Cost-effective, high performance video interface circuit

References

HCPL-4562 Wideband Analog/Video Optocoupler Technical Data

Alternative Avago Parts

HCNW4562 Widebody Wideband Analog/Video Optocoupler

Inverter Design Using Gate Drive and Current Sense Optocouplers

System Overview

A typical motor drive and power control system shown in Figure 1 requires isolation between the high voltage devices (IGBT/MOSFET) and the low voltage devices (micro-controller). In addition to meeting the severe requirements for the isolation function, Avago Technologies optocouplers provide customized functionality such as direct gate drive for IGBTs or power MOSFETs, and analog isolation for motor current sensing, voltage sensing, speed measurement, and position measurement.

Isolated Gate Drive and IPM Interface

Many motor drive and power control systems use pulse width modulation switching of power devices to generate a three phase variable voltage and variable frequency power source. High performance motor drives require precision timing for turning on and turning off the power devices on the inverter. The micro-controller that controls the turn-on and turn-off of these power devices needs to be isolated from the high voltage inverter side. Avago Technologies offers a variety of optocouplers that have built-in gate drive capability. For solutions that require only a simple isolation interface, Avago provides

Intelligent Power Module (IPM) interface optocouplers. All of Avago's gate drive and IPM interface optocouplers meet stringent industrial requirements with critical performance:

- Minimum Common Mode Rejection: 10 kV/ μ s slew rate at 1,500 V peak transients
- Wide Operating Temperature Range: -40°C to +85°C
- Over Current Protection and Fault Feedback (HCPL-316J)
- Safety Standards Certifications: UL, CSA, IEC/EN/DIN EN 60747-5-2
- Fast Switching Speeds: 500 ns range (see detailed part number specifications)
- Wide Supply Voltage Range: 15 V to 30 V

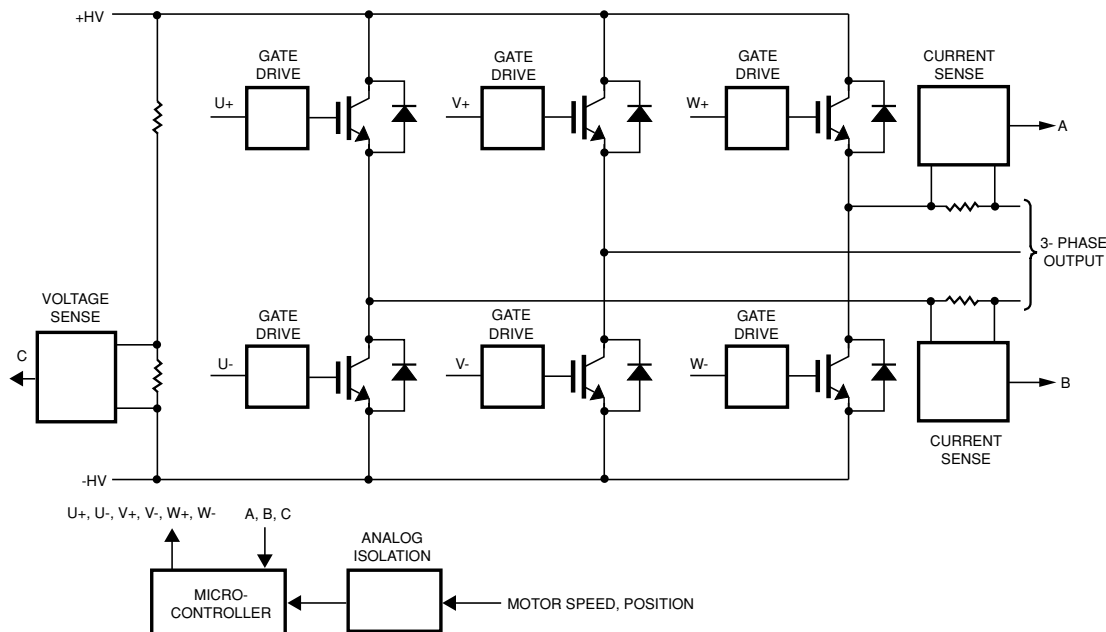

Figure 1. Isolation Circuits for Power Control – System Overview

MOTOR CONTROL APPLICATIONS

Isolated Current and Voltage Sensing

Avago Technologies provides several analog isolation amplifier products for isolated precision current and voltage sensing for monitoring motor performance. Avago also offers a digital output isolation amplifier for direct connection to a micro-controller. Compared to Hall-Effect sensors, Avago's isolation amplifiers have excellent gain and offset characteristics, especially very low offset drift over a wide temperature range. In addition, they provide a compact, low-cost, and reliable solution for motor drive designers that need to accurately measure motor voltage and current. Some of the key performance features include:

- 12-bit linearity (HCPL-7860)
- over current detection (HCPL-788J)
- ± 200 mV input range
- -40°C to $+85^{\circ}\text{C}$ operating temperature range
- $15\text{ kV}/\mu\text{s}$ isolation transient immunity
- Safety Standards Certifications: UL, CSA, IEC/EN/DIN EN 60747-5-2

Analog Signal Isolation for Speed and Position Measurement

Avago Technologies offers a low cost, high accuracy, isolated amplifier solution for the measurement of speed and position in a motor. With the use of Avago Technologies' HCNR201 and low cost operational amplifiers, circuit designers have the flexibility of designing analog isolation amplifiers that have low input bias currents, high bandwidth, stable gain, and very high linearity.

Common Mode Rejection

The detector shield in the optocoupler prevents CMR failure due to capacitive coupling from the input side of the optocoupler, through the package, to the detector IC. However, this shield does not eliminate the capacitive coupling between the LED and the optocoupler output pins and output ground as shown in Figure 2. This capacitive coupling causes perturbations in the LED current during common mode transients and becomes the major source of CMR failures for a shielded optocoupler. The main design objective of a high CMR LED drive circuit becomes keeping the LED in the proper state (on or off) during common mode transients. The recommended application circuits for Avago's gate drive applications can achieve $15\text{ kV}/\mu\text{s}$ CMR while minimizing component complexity.

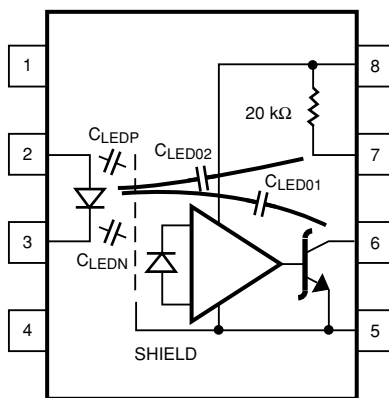

Figure 2. AC Equivalent for a Digital Optocoupler

Another cause of CMR failure for a shielded optocoupler is direct coupling to the optocoupler output pins through C_{LED01} and C_{LED02} in Figure 2. Many factors influence the effect and magnitude of the direct coupling including: the use of an internal

or external output pull-up resistor, the position of the LED current setting resistor, the connection of the unused input package pins, and the value of the capacitor at the optocoupler output (CL). The recommended gate drive and IPM interface application circuits for Avago optocouplers have been optimized to reduce the likelihood of CMR failure.

IPM Dead Time and Propagation Delay Specifications

Many of Avago's gate drive and IPM interface optocouplers include a Propagation Delay Difference (PDD) specification intended to help designers minimize "dead time" in their power inverter designs. Dead time is the time periods during which both the high and low side power transistors (Q_1 and Q_2) of a power module are off. Any overlap in Q_1 and Q_2 conduction will result in large currents flowing through the power devices between the high and low voltage motor rails.

To minimize dead time the designer must consider the propagation delay characteristics of the optocoupler as well as the characteristics of the IGBT gate drive circuit. Considering only the delay characteristics of the optocoupler (the characteristics of the IGBT gate drive circuit can be analyzed in the same way) it is important to know the minimum and maximum turn-on (t_{PHL}) and turn-off (t_{PLH}) propagation delay specifications, preferably over the desired operating temperature range.

MOTOR CONTROL APPLICATIONS

The limiting case of zero dead time occurs when the input to Q1 turns off at the same time that the input to Q2 turns on. This case determines the minimum delay between LED₁ turn-off and LED₂ turn-on, which is related to the worst case optocoupler propagation delay waveforms, as shown in Figure 3. A minimum dead time of zero is achieved in Figure 3 when the signal to turn on LED₂ is delayed by $(t_{PLH\ max} - t_{PHL\ min})$ from the LED₁ turn off. Note that the propagation delays used to calculate PDD are taken at equal temperatures since the optocouplers under consideration are typically mounted in close proximity to each other.

(Specifically, $t_{PLH\ max}$ and $t_{PHL\ min}$ in the Figure 3 equations are not the same as the $t_{PLH\ max}$ and $t_{PHL\ min}$, over the full operating temperature range, specified in the data sheet.). This delay is the maximum value for the propagation delay difference specification that is specified at 450 ns for the HCPL-4506 over an operating temperature range of -40°C to +100°C. Delaying the LED signal by the maximum propagation delay difference ensures that the minimum dead time is zero, but it does not tell a designer what the maximum dead time will be. The maximum dead time occurs in the highly unlikely case where one optocoupler with the fastest t_{PLH} and another with the slowest t_{PHL} are in the same inverter leg. The maximum dead time in this case becomes the sum of the spread in the t_{PLH} and t_{PHL} propagation delays as shown in Figure 3.

The maximum dead time is also equivalent to the difference between the maximum and minimum propagation delay difference specifications. The maximum dead time (due to the optocouplers) for the HCPL-4506 is 600 ns over an operating temperature range of -40°C to +100°C.

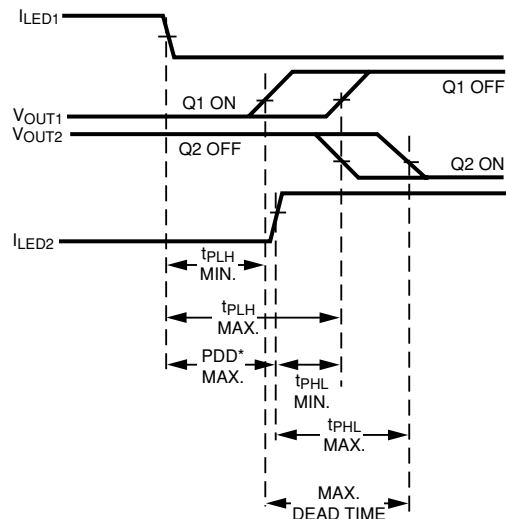

MAXIMUM DEAD TIME (DUE TO OPTOCOUPLER)

$$= (t_{PLH\ MAX.} - t_{PHL\ MIN.}) + (t_{PHL\ MAX.} - t_{PHL\ MIN.})$$

$$= (t_{PLH\ MAX.} - t_{PHL\ MIN.}) + (t_{PLH\ MIN.} - t_{PHL\ MAX.})$$

$$= PDD^* MAX. - PDD^* MIN.$$

PROPAGATION DELAY DIFFERENCE (PPD) MAX.

$$= (t_{PLH} - t_{PHL}) MAX. = (t_{PLH\ MAX.} - t_{PHL\ MIN.})$$

NOTE: THE PROPAGATION DELAYS USED TO CALCULATE THE PDD AND MAXIMUM DEAD TIME ARE TAKEN AT EQUAL TEMPERATURES.

Figure 3. Propagation Delay and Dead Time

MOTOR CONTROL APPLICATIONS

Bootstrap Power Supply Circuit for Power Control Systems

Figure 4 shows a bootstrapped output power supply circuit that has the following benefits:

- eliminates the need for an isolated power supply or a dc-to-dc converter,
- lower cost solution compared to transformer based power supply,
- less printed circuit board space.

This circuit includes a bootstrap circuit for providing output power to the HCPL-316J gate drive optocouplers, thereby

eliminating the need for isolated power supplies or dc-to-dc converters. It can be modified to suit other Avago gate drive optocouplers and current/voltage sensing isolation amplifiers.

Component values were chosen for a 350 V rail =
 $HV+ - HV - (240 \text{ V} \times 1.414)$.
 When the lower IGBT is turned on, V_{C1H} charges up (through D_{1H}) to a voltage of:

$$\begin{aligned}
 V_{C1H} &= HV+ - [HV- + V_{SATM2} + V_{CC2H} + V_F(D_{1H})] \\
 &= 350 \text{ V} - 3 \text{ V} - 18 \text{ V} - 1 \text{ V} \\
 &= 328 \text{ V}
 \end{aligned}$$

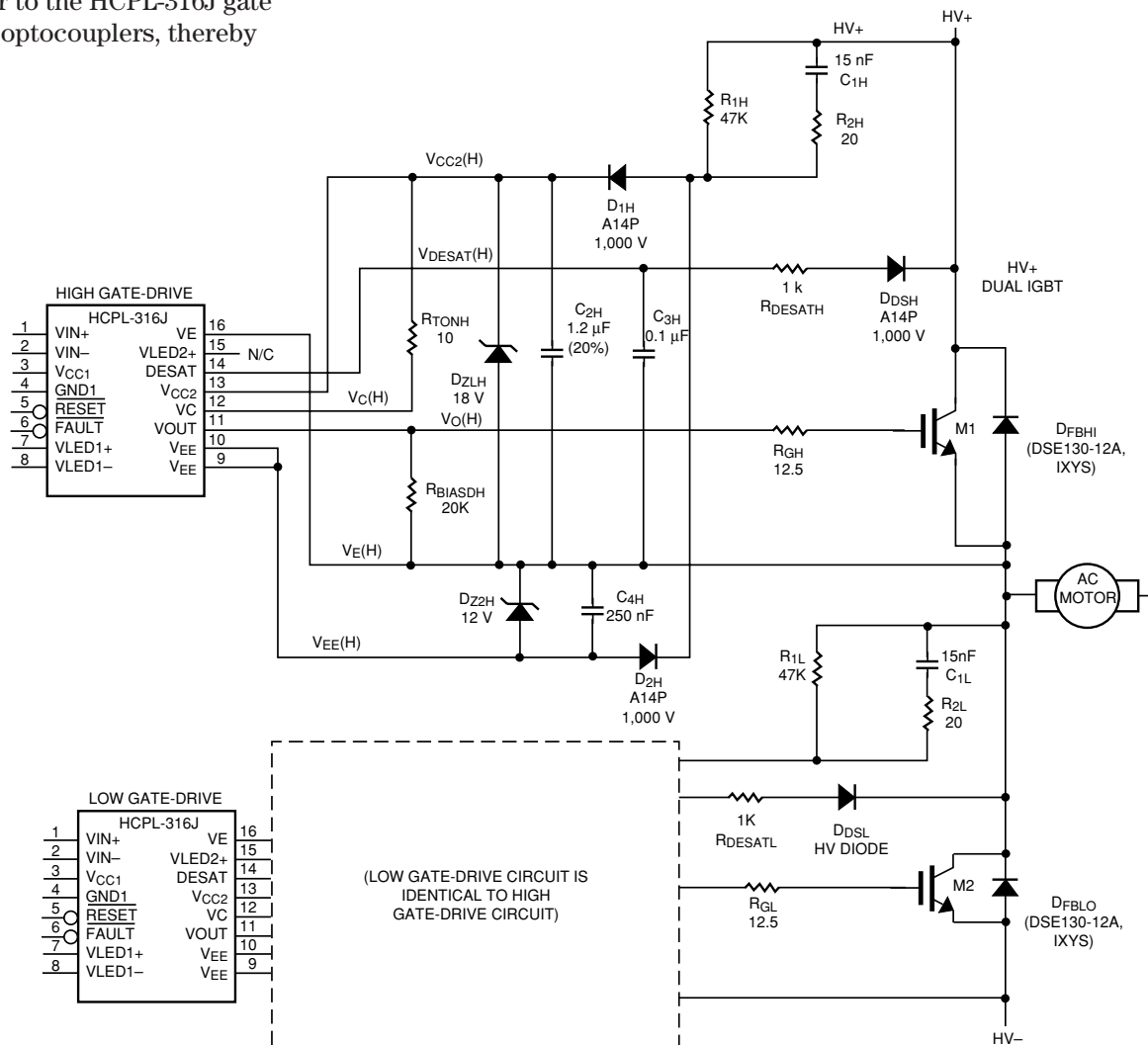

Figure 4. Bootstrap Circuit for Power Control System

MOTOR CONTROL APPLICATIONS

where V_{SATM2} is the saturation or “on” voltage across the collector-emitter of IGBT M2; $V_{F(D1H)}$ is the voltage across diode D_{D1H} ; and $HV+$, $HV-$ are the rail voltages.

When M2 (low IGBT) switches off and M1 (upper IGBT) switches on, $V_{E(H)}$ pulls up to $HV+ - V_{SATM1}$. This causes C_{4H} to become charged through D_{2H} . Charge sharing between C_{1H} and C_{4H} results in the voltage across C_{4H} which (in the absence of clamping diode D_{Z2H}) can be approximated by:

$$C_{4H} \times \Delta V_{C4H} = C_{1H} \times 328 V$$

$$\rightarrow \Delta V_{C4H} = 19.6 V$$

where ΔV_{C4H} = the voltage drop across C_{4H} . The negative gate bias then is held at 12 V by clamping Zener D_{Z2H} .

Shunt Resistor Selection for Current Sensing

The current-sensing shunt resistor should have low resistance to minimize power dissipation, low inductance to minimize di/dt induced voltage spikes which could adversely affect operation, and reasonable tolerance to maintain overall circuit accuracy. Choosing a particular value for the shunt is usually a compromise between minimizing power dissipation and maximizing accuracy. Smaller shunt resistance decrease power dissipation, while larger shunt resistance can improve circuit accuracy by utilizing the full input range of the isolated modulator.

Avago Technologies recommends Dale Electronics’ two-terminal shunt resistors for low cost

applications. These resistors are suitable for measuring current up to $28 A_{RMS}$. See comparison table below.

Several four-terminal shunts from Isotek suitable for sensing currents in motor drives up to $71 A_{RMS}$ (71 hp or 53 kW) are shown in the comparison table below; the maximum current and motor power range for each of the PBV-series shunts are indicated. For shunt resistance from 50 mW down to 10 mW, the maximum current is limited by the input voltage range of the isolated modulator. For the 5 mW and 2 mW shunts, a heat sink may be required due to the increased power dissipation at higher currents.

Low Cost Two Terminal Resistor Selection Guide (Supplier: Dale Electronics, Tel: 402-564-3131)

Shunt Resistor Part Number	Shunt Resistance (mΩ)	Price Range (US\$)	Tolerance (%)	Temp. Coefficient (ppm/°C)	Max. RMS Current (A)	Motor Power Range 120 Vac - 440 Vac	
						(hp)	(kW)
LV-5.005	5	\$0.40 - 1.00	1	<300	28.3	8 - 28	6 - 21
LVR-3.01	10	\$0.38 - 0.76	1	<300	14.1	4 - 14	3 - 10
LVR-3.02	20	\$0.38 - 0.76	1	<300	7	2 - 7	1.4 - 5
LVR-3.05	50	\$0.38 - 0.76	1	<300	2.8	0.8 - 3	0.6 - 2
WSC-2.02*	20	\$0.38 - 0.76	1	<300	7.1	2 - 7	1.4 - 5

* Surface Mount

High Performance Four-Terminal Shunt Resistor Selection Guide (Supplier: Isotek, Tel: 508-673-2900)

Shunt Resistor Part Number	Shunt Resistance (mΩ)	Unit Price @ 2500 Qty. (US\$)	Tolerance (%)	Temp. Coefficient (ppm/°C)	Max. RMS Current (A)	Motor Power Range 120 Vac - 440 Vac	
						(hp)	(kW)
PBV-R050-0.5	50	\$3.74	0.5	<30	3	0.8 - 3	0.6 - 2
PBV-R020-0.5	20	\$3.74	0.5	<30	7	2 - 7	1.4 - 5
PBV-R010-0.5	10	\$3.74	0.5	<30	14	4 - 14	3 - 10
PBV-R005-0.5	5	\$4.09	0.5	<30	25 [28]	7-25 [8-28]	5-19 [6-21]
PBV-R002-0.5	2	\$4.09	0.5	<30	39 [71]	11 - 39 [19 - 71]	8 - 29 [14 - 53]

Note: Values in brackets are with a heatsink for the shunt.

MOTOR CONTROL APPLICATIONS

Isolated Integrated Gate Driver for IGBT/MOSFET

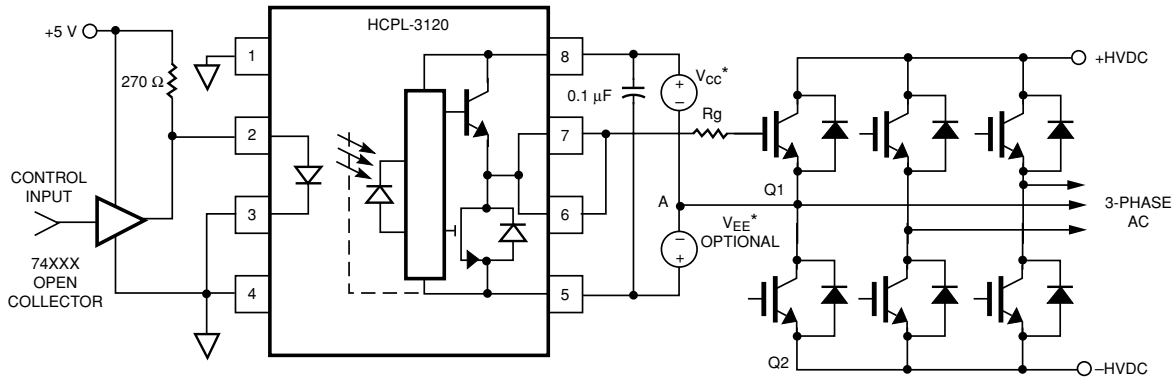

*RECOMMENDED SUPPLY VOLTAGES

SINGLE SUPPLY	V _{CC} = +18V	V _{EE} = 0V
DUAL SUPPLY	V _{CC} = +15V	V _{EE} = -5V

$$R_g = \frac{V_{CC} - V_{EE} - V_{OL}}{I_{ON}}$$

Description

The HCPL-3120 drives the IGBTs or MOSFETs directly in this circuit and provides full regulatory approved isolation between the power and control circuits. The output power supply can be derived from rail to rail supply by using a bootstrap circuit illustrated in the “Inverter Design using Gate Drive and Current Sense Optocoupler” section. The value of R_g in the above circuit is chosen to control the peak gate charge and discharge current as well as the output power dissipation.

Performance of Circuit

- Peak output current of 2.0A improves driving efficiency.
- Superior common mode transient noise immunity: 15 kV/μs@V_{cm} = 1500 V.
- Low I_{cc} current and wide V_{cc} range: 15 V - 30 V over -40°C to 100°C.
- Low V_{OL} of 0.5 V eliminates the need for negative Supply Voltage (V_{ee}).
- World wide regulatory approval.
- Fast under voltage lockout response: 0.6 μs.

Alternative Avago Parts

- 1) HCPL-3150 0.5 Amp Isolated IGBT Gate Driver
- 2) HCPL-3140 0.4 amp Isolated IGBT Gate driver
- 3) HCPL-314J 0.4 Amp Dual IGBT Gate Driver
- 4) HCPL-315J 0.5 Amp Dual IGBT Gate Driver
- 5) HCPL-316J 2.0 Amp Isolated Gate Driver with Integrated Desaturation Detection and Feedback.

MOTOR CONTROL APPLICATIONS

Dual Channel Isolated Integrated Gate Driver for IGBT/MOSFET

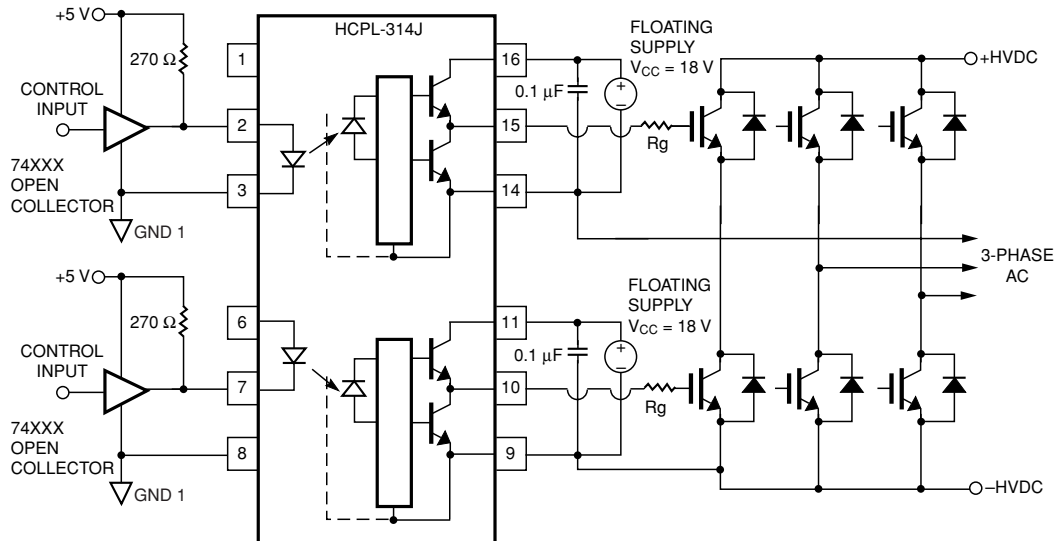

Description

The HCPL-314J drives 2 IGBTs or MOSFETs directly in this circuit and provides full regulatory approved isolation between the power and control circuits. The output power supply can be derived from rail to rail supply by using a bootstrap circuit illustrated in the “Inverter Design using Gate Drive and Current Sense Optocoupler” section. The value of R_g in the above circuit is chosen to control the peak gate charge and discharge current as well as the output power dissipation.

Performance of Circuit

- Dual in 1 package saves assembly costs.
- Peak output current of 0.4 A best suited for low and medium power IGBTs.
- Superior common mode transient noise immunity: $10 \text{ kV}/\mu\text{s}@V_{cm} = 1500 \text{ V}$.
- Low I_{cc} current and wide V_{cc} range: 10 V - 30 V over -40°C to 100°C .
- Low V_{OL} of 1V eliminates the need for negative supply voltage (V_{ee}).
- Worldwide regulatory approval.

Alternative Avago Parts

- 1) HCPL-315J 0.5 Amp Dual IGBT Gate Driver
- 2) HCPL-3150 0.5 Amp Isolated IGBT Gate Driver
- 3) HCPL-3140 0.4 amp Isolated IGBT Gate driver
- 4) HCPL-3120 2.0 Amp IGBT Gate Driver
- 5) HCPL-316J 2.0Amp Isolated Gate Driver with Integrated Desaturation Detection and Feedback.

MOTOR CONTROL APPLICATIONS

Isolated Gate Drive for IGBT/MOSFET with Integrated Desaturation Protection and Fault Feedback

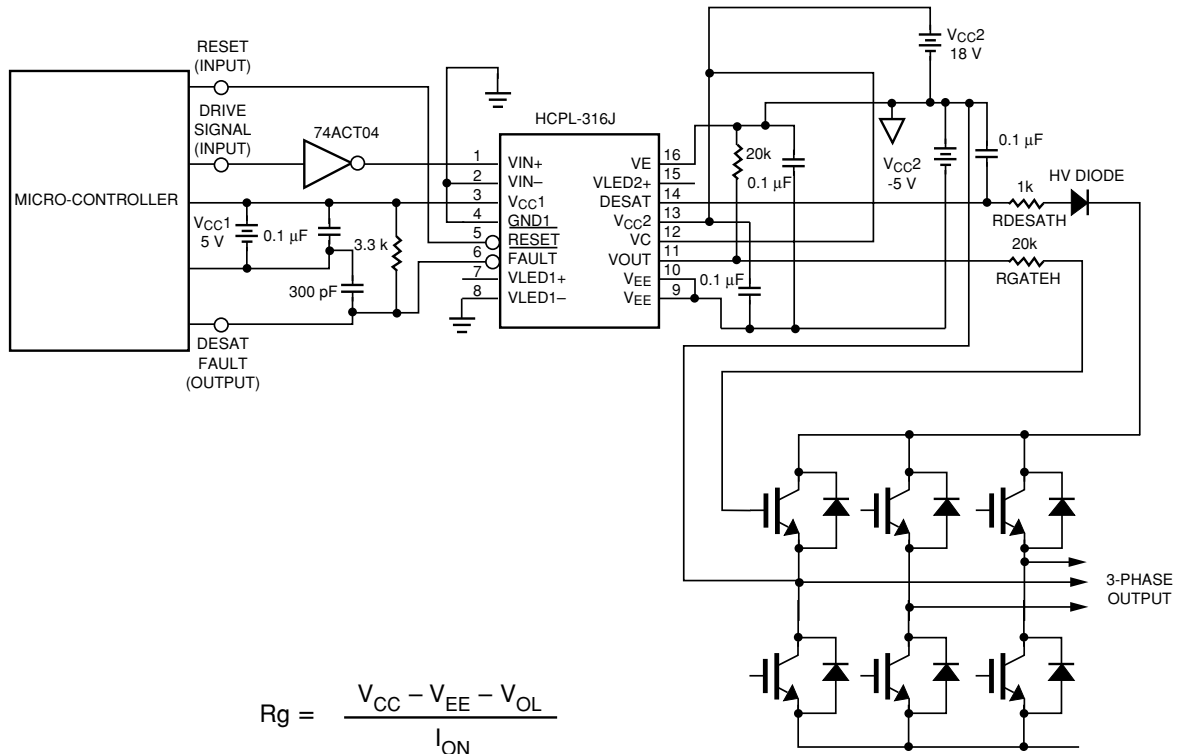

Description

The HCPL-316J drives IGBTs or MOSFETs directly and provides additional IGBT desaturation protection. The Vce of the IGBT is monitored by Desat pin and the IGBT will be slowly turned off if Vdesat exceeds a threshold of 7 V. A fault feedback signal is propagated to the input side to notify the micro-controller of the detected fault condition. This FAULT output remains low until the part is reset. The 100 pF blanking capacitor shown in the diagram above will delay the rise of VDesat for a period of around 4 µs to allow the IGBT sufficient time to turn on and the collector to settle to a low VDesat.

Performance of Circuit

- Gate Drive Current : 2.0 A
- Common mode Transient Rejection: 15 kV/µs@V_{CM} = 1.5 kV
- IGBT gate protection response time: 3 µs.
- IGBT fault signal propagation delay: 10 µs.

Benefits:

- Reduced assembly costs
- CMOS/TTL compatible
- Local IGBT soft shutdown
- Worldwide regulatory approval

Alternative Avago Parts

- 1) HCPL-315J 0.5 Amp Dual IGBT Gate Driver
- 2) HCPL-3150 0.5 Amp Isolated IGBT Gate Driver
- 3) HCPL-J314 0.4 amp Isolated IGBT Gate driver
- 4) HCPL-314J 0.4 Amp Dual IGBT Gate Driver
- 5) HCPL-3120 2.0Amp Isolated Gate Driver.

MOTOR CONTROL APPLICATIONS

Isolated Interface for Intelligent Power Module Gate Drive

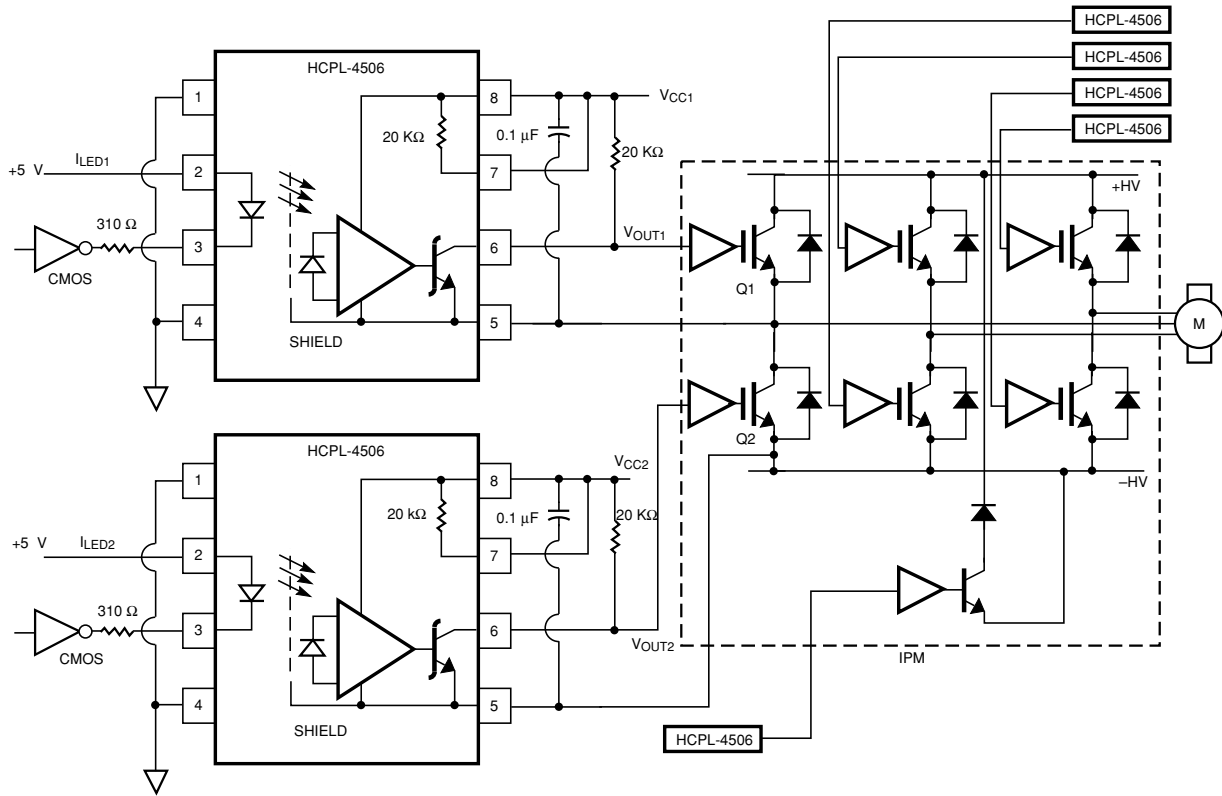

Description

The HCPL-4506 provides isolation between the controller and the IPM (Intelligent Power Module). This optoisolator provides world wide safety certification (UL, CSA, IEC/EN/DIN EN 60747-5-2). The HCPL-4506 optocouplers can reject common mode transients that have slew rates as high as 15 kV/μs and peak voltage up to 1500 V. Furthermore, this optocoupler has guaranteed Pulse Width Distortion and Propagation Delay Difference specifications that allow the circuit designer to reduce switching dead time and improve inverter efficiency.

Performance of Optocoupler

- Minimum 15 kV/μs transient immunity
- Maximum propagation delay: 500 ns
- Maximum propagation delay difference between any two HCPL-4506s: 450 ns
- Specification guaranteed over -40°C to 100°C operating temperature range.

Benefits

- World wide regulatory approval.
- Reduced deadtime

Alternative Avago Parts

- 1) HCNW4506 widebody, $V_{IORM} = 1414$ V, HCPL-J456, $V_{IORM} = 891$ V, HCPL-0456, SO8 package.
- 2) HCPL-4504, CNW4504, HCPL-J454, HCPL-0454.
- 3) HCPL-4503, HCNW4503, HCPL-0453.

MOTOR CONTROL APPLICATIONS

Low Cost Isolated Phase Current Sensing with Analog Output

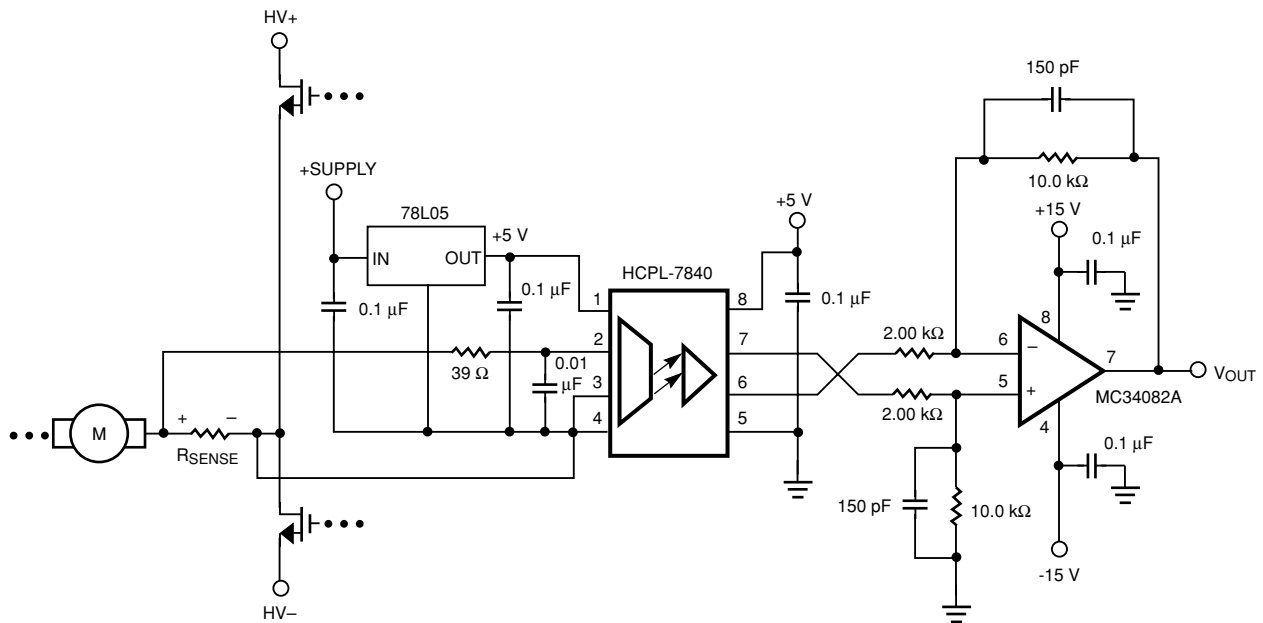

Description

The HCPL-7840 Isolation Amplifier can be used for isolating the motor current sensing element from the control circuit while at the same time transmitting precision analog signals. This circuit requires a low cost shunt resistor for monitoring the motor current. The voltage across the sensing resistor is fed to the HCPL-7840 input pins 2 and 3. A floating power supply (which in many applications could be the same one used to drive the high side power transistors) is regulated to 5 V using a simple three-terminal voltage regulator, 78L05. The differential output from the HCPL-7840 isolation amplifier is converted to a ground-referenced single-ended output voltage with a simple differential amplifier circuit (MC34082A and associated components).

Performance of Circuit

- Sense current: Up to 200 A
- Optocoupler bandwidth: Up to 100 kHz
- Optocoupler nonlinearity: 0.2%
- Optocoupler input offset voltage: 0.2 mV (typical)
- Optocoupler common-mode rejection: 15 kV/ μ s

Benefits

- Small size and lower profile circuit compared to Hall-Effect device current sensing circuits.
- Industry standard low profile components are used in this circuit.
- High precision measurement while maintaining common mode transient immunity.

Alternative Avago Parts

- 1) HCPL-7800A: 1% part-to-part gain tolerance, HCPL-7800: 3% part-to-part gain tolerance.
- 2) HCPL-788J: single ended output isolation amplifier with integrated over current detection.
- 3) HCPL-7860 and HCPL-7870/ HCPL-0870: isolated 15 bit A/D converter.
- 4) HCPL-786J: isolated 15 bit A/D converter.

MOTOR CONTROL APPLICATIONS

Isolated A/D Converter for Phase Current Sensing

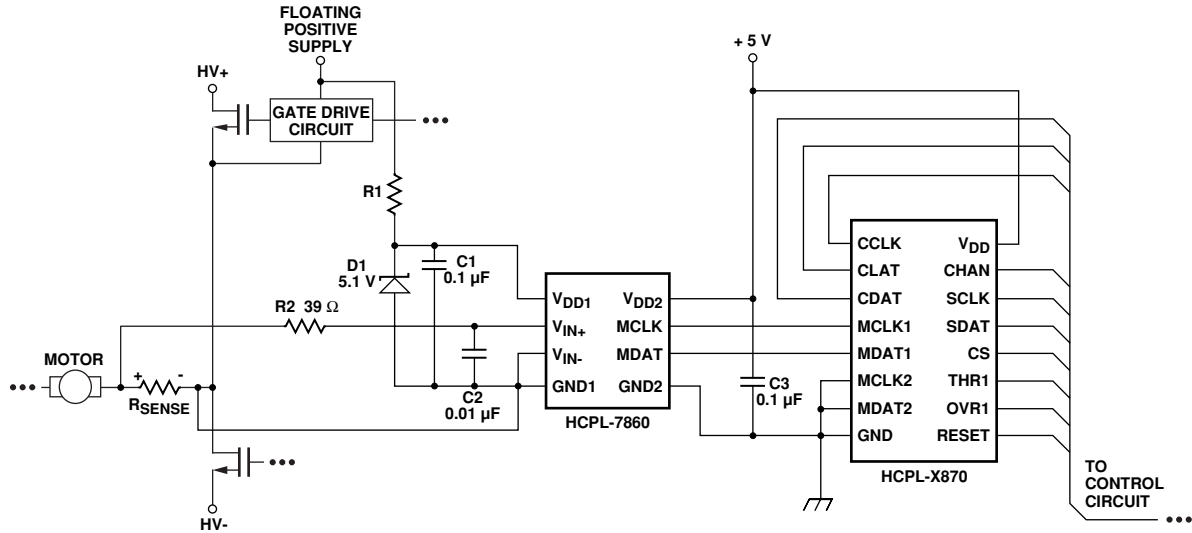

Description

The HCPL-7860 Isolated Modulator and the HCPL-x870 Digital Interface IC together form an isolated programmable two-chip analog-to-digital converter. The isolated modulator allows direct measurement of motor phase currents in power inverters while the digital interface IC can be programmed to optimize the conversion speed and resolution.

Performance of Circuit

- Resolution due to linearity: 12 bits at $t_{\text{DELAY}} = 18 \mu\text{s}$, 14 bits at $t_{\text{DELAY}} = 94 \mu\text{s}$
- Common-mode transient rejection: $dV/dt = 15 \text{ kV}/\mu\text{s}$ @ $V_{\text{CM}} = 1500 \text{ V}$
- Signal-to-Noise: $\text{SNR} = 62 \text{ dB}$ (minimum)
- Regulatory Isolation Ratings: $V_{\text{ISO}} = 3750 \text{ V}$ (per UL 1577), $V_{\text{IORM}} = 848 \text{ V}$; $V_{\text{IOTM}} = 6000 \text{ V}$
- Input Offset Drift: $4 \mu\text{V}/^\circ\text{C}$ (typical)
- Reference Voltage Tolerance: $\pm 4\%$ ($\pm 1\%$ within shipment tube)

Benefits

- Integrated analog-to-digital converter means fewer components required.
- High common-mode transient rejection ensures no corruption of data.
- Low gain temperature-coefficient and offset voltage ensure high accuracy measurements.

References

- 1) HCPL-7860/x870 Technical Data
- 2) High precision current sensing resistor suppliers: Dale in USA; Isabellenhutte in Germany; and PCN in Japan

MOTOR CONTROL APPLICATIONS

Low Cost Isolated Phase Current Sensing with Analog Output and Over Current Detection

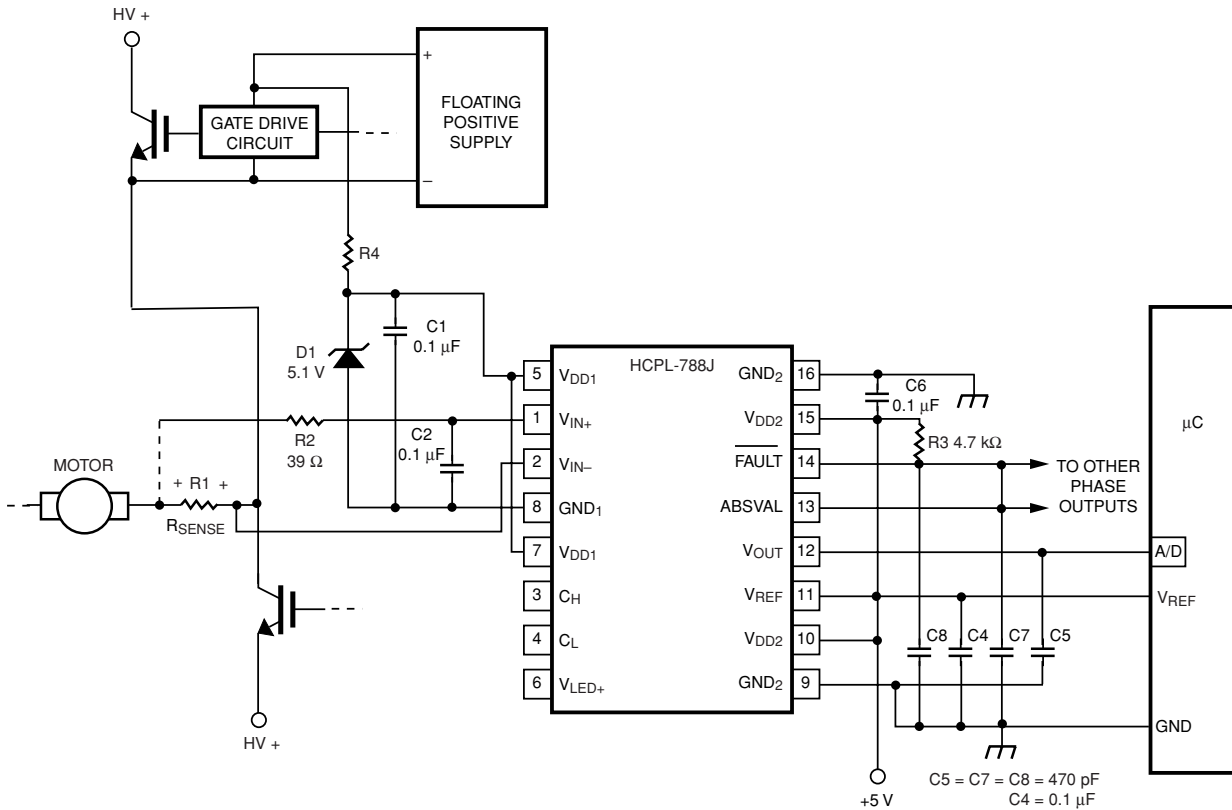

Description

The HCPL-788J can be used for isolating the motor current sensing element from the control circuit while at the same time transmitting precision analog signals and over current fault signal. This circuit requires a high precision-sensing resistor for monitoring the motor current. The voltage across the sensing resistor is fed to the HCPL-788J input pins 2 and 3. The single-ended output allows it to interface directly with the A/D port of the micro-controller. The sensing resistor is available from several suppliers, which are listed in the “Inverter Design using Gate Drive and Current Sense Optocoupler” section.

Performance of Circuit

- Overcurrent fault response: 3 μs typical
- Sense current up to 100 A or more
- Bandwidth: 30 kHz typical
- Nonlinearity: 0.06% typical
- Input offset voltage: 3 mV max. over temp.
- Common-mode rejection: 10 kV/μs@V_{CM} = 15 kV min.

Benefits

- No additional fault detection circuitry needed
- Direct interface with micro-controller
- Smaller size and lower profile compared to Hall-Effect device based current sensing circuits
- High precision measurement while at the same time maintaining transient immunity

MOTOR CONTROL APPLICATIONS

Isolated Inverter Rail Voltage Sensing using an Isolation Amplifier

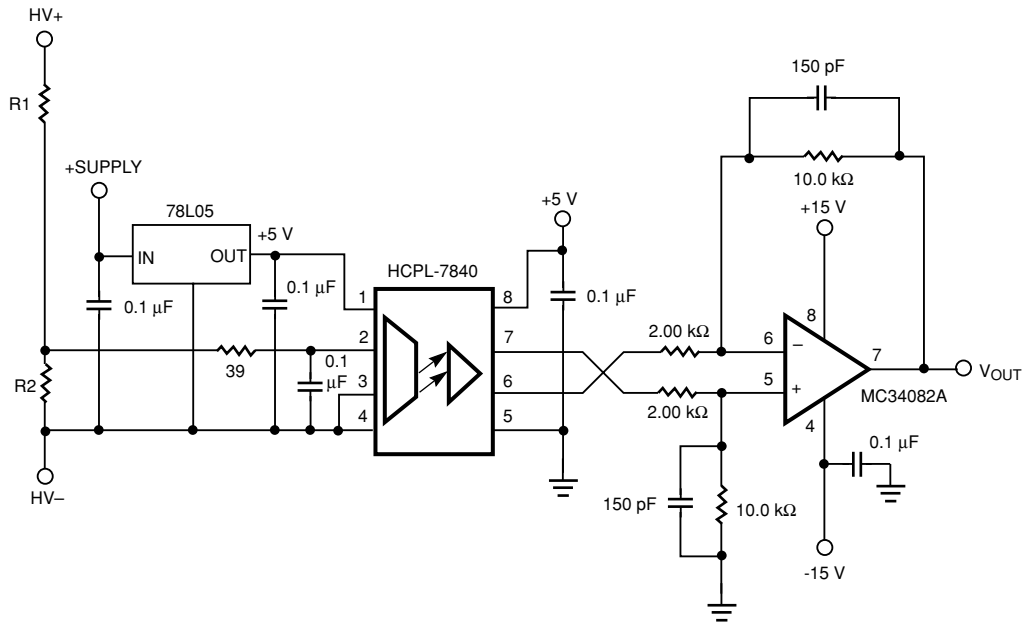

Description

The HCPL-7840 isolation amplifier can be used for sensing the rectified dc power supply voltage in a power inverter. An isolated 5 V power supply regulated to 5 V using a simple three-terminal voltage regulator powers the HCPL-7840 input circuit. The resistor divider network is used so that the full scale voltage at the HCPL-7840 input is 200 mV. The impedance of the resistor divider must be less than 1 kΩ so that the input resistance (500 kΩ) and input bias current (1 mA) of the isolation amplifier do not affect the accuracy of the measurement. To obtain higher bandwidths, the input bypass capacitor (across HCPL-7840's pins 2 and 3) can be reduced, but it should not be reduced much below 1000 pF to maintain gain accuracy of the isolation amplifier.

Performance of Circuit

- 15 kV/μs transient rejection
- 0.05% nonlinearity
- 5% gain tolerance

Benefits

- Few components
- High electrical noise immunity

Avago Alternative Parts

- 1) HCPL-786J: isolated 15 bit A/D converter

References

- 1) HCPL-7860/x870 Technical Data
- 2) High precision current sensing resistor suppliers: Dale in USA; Isabellenhutte in Germany; and PCN in Japan

MOTOR CONTROL APPLICATIONS

Isolated Inverter Rail Voltage Sensing using a Linear Optocoupler

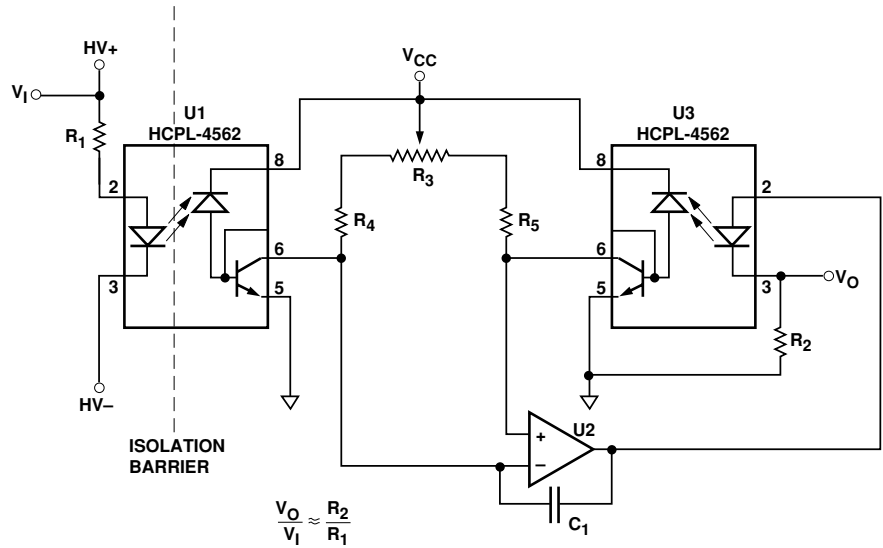

Description

The HCPL-4562 Linear Optocoupler is used in a servo circuit to sense the rectified dc power supply voltage of a power inverter. The series resistor R_1 limits the current that drives the input LED of optocoupler U1. The forward current through the LED of the HCPL-4562 optocoupler is proportional to the dc high voltage power supply rail.

When the circuit is balanced with the potentiometer R3, the output voltage V_O is proportional to the high voltage dc power supply as shown by the equation:

$$V_O / V_I = R_2 / R_1$$

Performance of Circuit

- 122 dB isolation mode rejection ratio
- 0.25% nonlinearity
- $\pm 0.3\%/^{\circ}\text{C}$ gain variation temperature coefficient

Benefits

- No isolated 5 V input power supply is required for optocoupler U1
- Simple circuit

Alternative Avago Parts

- 1) HCPL-7800A: 1% part-to-part gain tolerance
- 2) HCPL-7800: 3% part-to-part gain tolerance

MOTOR CONTROL APPLICATIONS

Low Cost Isolation Amplifier for Motor Speed and Position Measurement

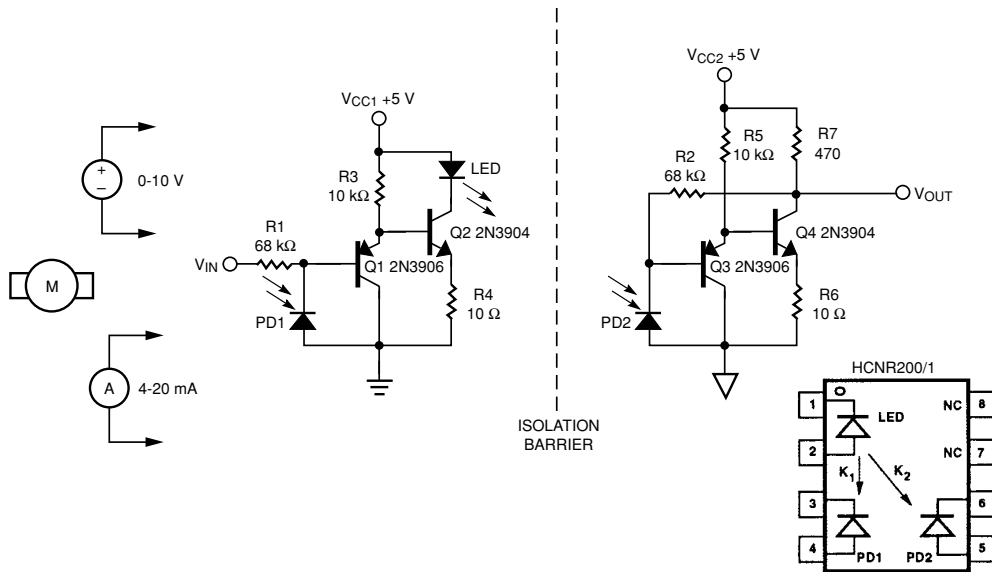

Description

This is a high-speed, low-cost isolation amplifier that can be used for the measurement of motor speed and position. The analog signal coming from the motor is assumed to be 0 to 10 V, or 4 to 20 mA. This circuit can be used in applications where high bandwidth, low-cost, and stable gain are required, but where accuracy is not critical. This circuit is a good example of how a designer can trade off accuracy to achieve improvements in bandwidth and cost. The circuit has a bandwidth of about 1.5 MHz with stable gain characteristics and requires few external components. R1 is selected to achieve an LED current of about

7 - 10 mA at the nominal input operating voltage according to the following equation:

$$I_F = (V_{IN} / R_1) / K_1$$

where K1 (i.e., I_{PD1} / I_F) of the optocoupler is typically about 0.5%. R2 is then selected to achieve the desired output voltage according to the equation, $V_{OUT} / V_{IN} = R_2 / R_1$. The purpose of R4 and R6 is to improve the dynamic response (i.e., stability) of the input and output circuits by lowering the local loop gains. R3 and R5 are selected to provide enough current to drive the bases of Q2 and Q4. And R7 is selected so that Q4 operates at about the same collector current as Q2.

Performance of Circuit

- 1.5 MHz bandwidth
- Stable gain
- Low-cost support circuit
- Circuit couples only positive voltage signals

Benefits

- Low cost solution for coupling positive voltage analog signals
- Simple way for isolating motor speed and position analog signals

AC/DC Voltage Threshold Sensing

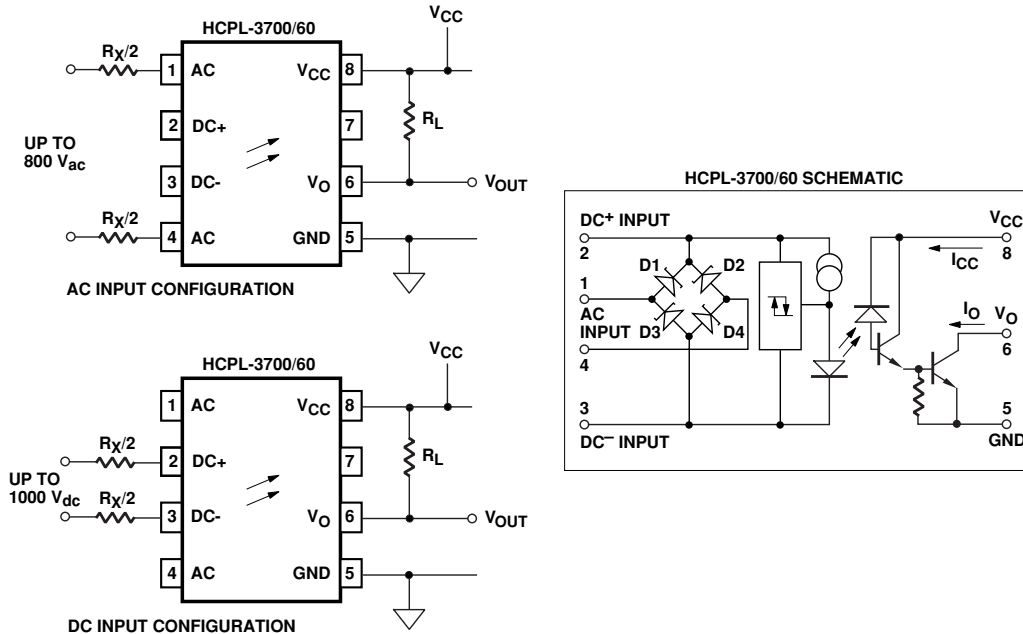

Description

The HCPL-3700/60 Threshold-Sensing Optocoupler can be used for sensing the ac/dc power on/off condition. At the optocoupler input, only a pair of series resistors $R_X/2$ are required to limit the current. The ac signal can be filtered with a capacitor at either the input or the output of the optocoupler. For more information refer to Avago Application Note AN 1004, “Threshold Sensing for Industrial Control Systems.” The value of R_X determines the threshold sensing voltage.

Performance of Circuit

- HCPL-3760 optocoupler threshold input current: 1.3 mA (typical)
- Typical optocoupler propagation delay: 10 μ s
- Optocoupler common mode transient immunity: 600 V/ μ s (typical)
- Maximum input voltage: up to 1000 Vdc, or 800 Vac

Benefits

- HCPL 3700/60’s built-in diode bridge and hysteresis circuit reduces component count
- HCPL-3760’s low threshold sensing current reduces power dissipation
- Threshold voltage can be adjusted by external resistor R_X

References

- 1) Avago Application Note AN 1004, “Threshold Sensing for Industrial Control Systems”
- 2) HCPL-3700/60 Threshold Sensing Optocoupler Technical Data

Alternative Avago Parts

HCPL-576X: Hermetically Sealed Threshold Sensing Optocoupler

INDUSTRIAL APPLICATIONS

Optical Isolation In Flat-Panel Displays

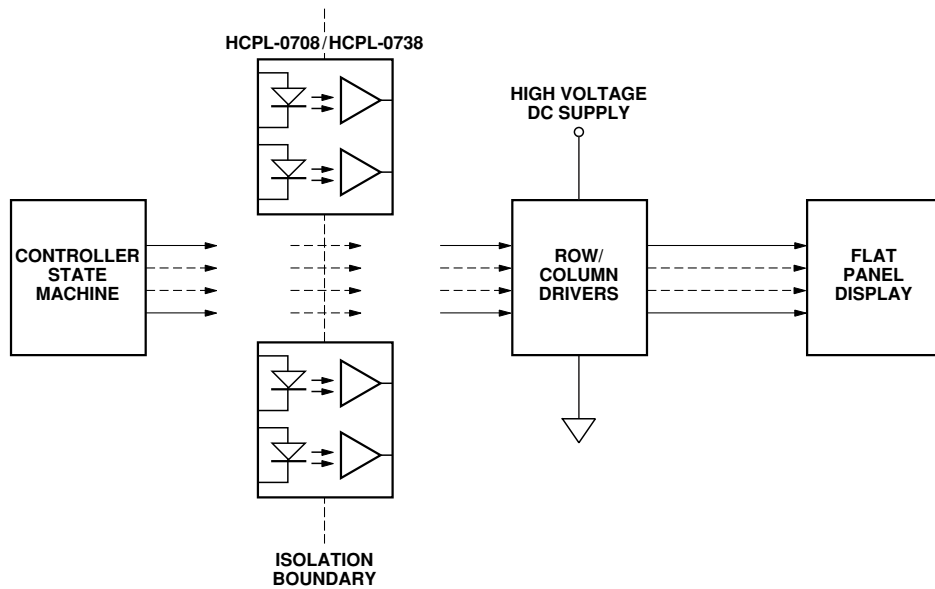

Description

The HCPL-0708 high-speed, optocoupler isolates the low-voltage logic circuit from the high-voltage Flat-Panel Display row/column drivers. Examples of Flat-Panel Display technologies requiring such high voltage technologies are Electro-Luminescence, Fluorescence, and Plasma technologies. The optocoupler serves the functions of level shifting and safety isolation.

Performance of Optocoupler

- Maximum propagation delay time: 60 ns
- Typical pulse width distortion of 15 ns
- Common-mode transient rejection: 15,000 V/ μ s at 1000 V peak

Benefits

- Compact size and easy interface compared to pulse transformers
- Low input current allowing CMOS interface
- Low component count

Alternative Avago Parts

- 1) HCPL-0201/11 Small Outline Low Input Current Optocoupler
- 2) HCPL-52XX Hermetically Sealed Low Input Current Optocoupler
- 3) HCNW-2201/11 Widebody Low Input Current Optocoupler
- 4) HCPL-2430/1 20 MBd Logic-Gate Optocoupler

Optical Isolation in a Switching Power Supply - Circuit No. 1

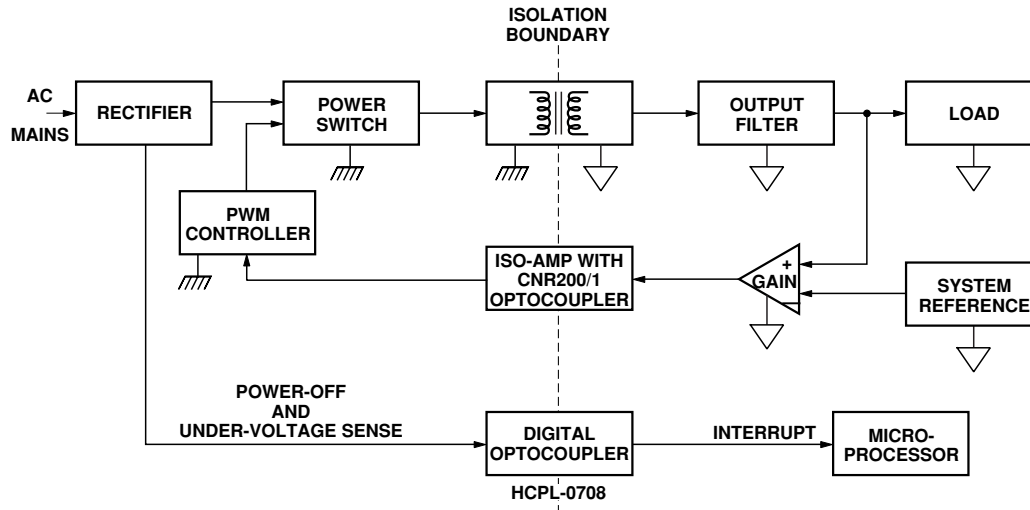

Description

Switching power supplies often need to couple digital and analog signals between the primary and secondary circuits. The above schematic shows an analog error signal representing the difference between the output voltage and the reference voltage being fed back to the primary side using a HCNR200/1 Analog Optocoupler. The analog error signal helps the pulse-width modulation (PWM) controller determine the exact pulse-width to make the filtered output voltage match the system reference voltage. In a similar manner, the HCPL-0708 Digital Optocoupler can be used to monitor the primary side power-off and under-voltage condition.

Performance of Optocoupler

- HCNR200/1 has 0.01% non-linearity and up to 1 MHz bandwidth
- HCPL-0708 has 60 ns maximum propagation delay time
- Both HCNR200/1 and HCPL-0708 optocouplers meet worldwide regulatory insulation guidelines

Benefits

- Accurate monitoring and control of secondary output voltage
- Power off condition detectable at an early stage enabling the microprocessor to save critical information

References

- 1) HCNR200/1 Analog Optocoupler Technical Data
- 2) HCPL-0708 High Speed Optocoupler Technical Data

Alternative Avago Parts

- 1) HCPL-7800 Isolation Amplifier
- 2) HCPL-4503, HCNW4503 High CMR Digital Optocoupler
- 3) HCNW2601/11 Widebody, High Speed Digital Optocoupler
- 4) 4N25, 4N35, CNY17, HCPL-181, HCPL-817 Phototransistor Optocouplers

Optical Isolation in a Switching Power Supply - Circuit No. 2

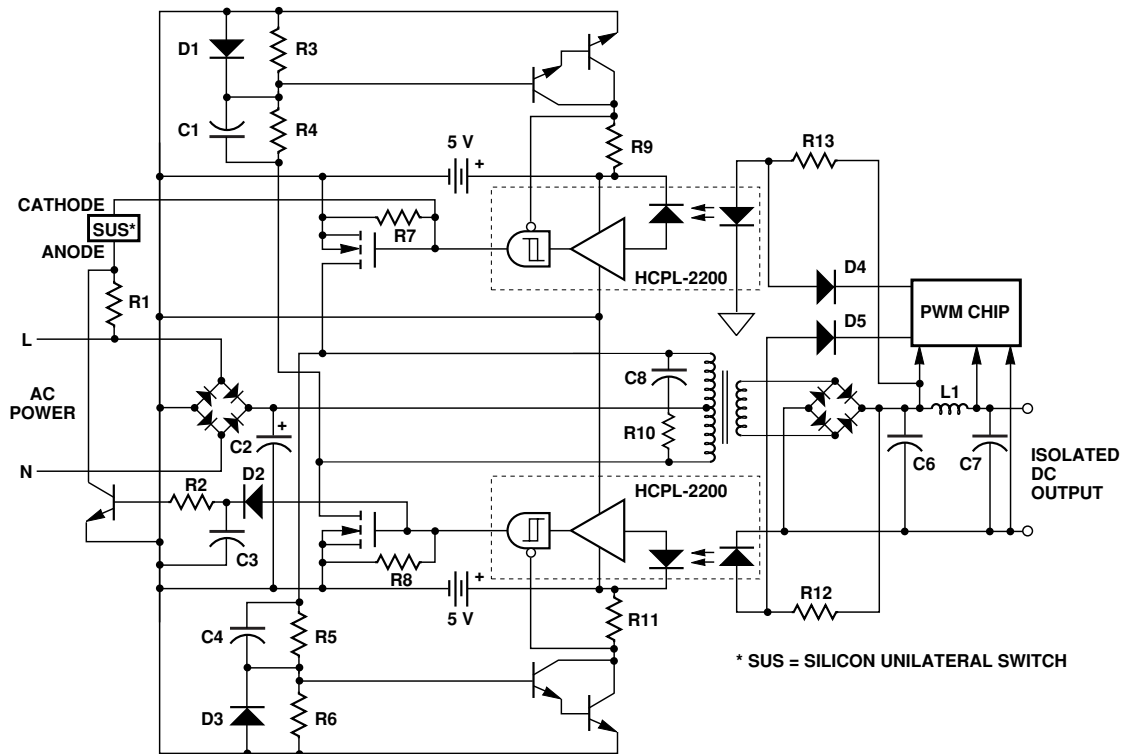

Description

The above figure shows a push-pull switching power supply that utilizes the HCPL-2200 optocoupler to drive switching transistors. The above circuit uses a silicon unilateral switch (SUS) to bootstrap start the power supply when power is first applied. The inhibit function in the HCPL-2200 optocoupler has been used to good advantage to provide a common-mode conduction interlock function that will not allow both the switching transistors to turn on at the same time.

Performance of Optocoupler

- Maximum propagation delay: 300 ns
- Input turn-on current: 1.6 mA
- Common-mode transient rejection: 1000 V/μs

Benefits

- The power switches are protected from common-mode conduction failures caused by EMI
- Regulation range is increased since no deadtime is required
- Design is tolerant to propagation delay changes due to lot-to-lot component variations

References

HCPL-2200 High CMR Optocoupler Technical Data

Alternative Avago Parts

- 1) HCPL-2219 Very High CMR Optocoupler
- 2) HCNW2601/11 Widebody High CMR Optocoupler

Optical Isolation in a DC/DC Converter

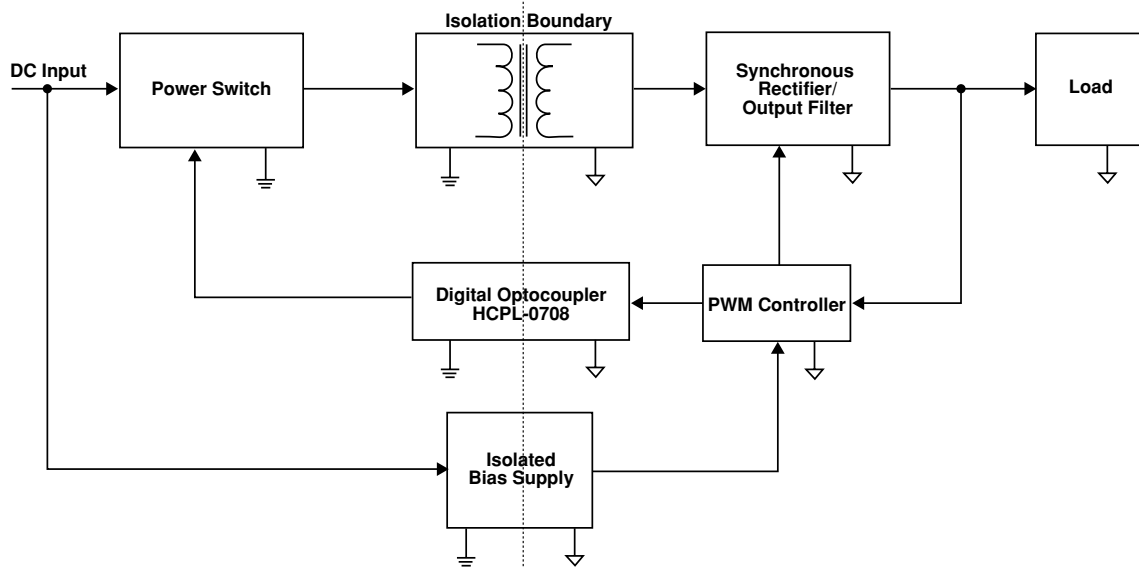

Description

The HCPL-0708 high speed optocoupler provides very good safety isolation between primary and secondary sections of the DC/DC converter as shown in the above figure. The switching frequency specification of the DC/DC converter is met by the low propagation delay (60 ns max.) and 15 ns typical pulse width distortion of HCPL-0708 CMOS compatible high speed optocoupler. The smaller size, better noise immunity performance, high reliability and wide operating temperature make HCPL-0708 ideally suited for such applications.

Performance of Optocoupler

- HCPL-0708: 60 ns maximum propagation delay time and 15 ns typical pulse width distortion
- 10KV/ μ s minimum CMR @ $V_{cm} = 1KV$
- Wide operating temperature: -40 to 100°C

Benefits

- Accurate monitoring and control of output voltage
- Low propagation delay
- Small size and high reliability
- CMOS compatible and easy interface

Alternative Avago Parts

- 1) HCPL-0600 High Speed Optocoupler
- 2) HCPL-2200 High CMR Optocoupler
- 3) 4N25, 4N35, CNY17, HCPL-181, HCPL-817 Phototransistor Optocouplers

Application Notes



The following application notes and technical articles are available on Avago Technologies' web site at

<http://www.avagotech.com/view/optocouplers>

They can also be obtained from your local Avago Technologies' sales office or authorized Avago distributor.

Pub. No	AN No	Title	Pub. Date
5988-6491EN	AB 102	Avago Optoisolation Product PN System	28/05/02
5964-3898E	AN 951-1	Applications for Low Input Current, High Gain Optocouplers	11/99
5954-8430	AN 951-2	Linear Applications of Optocouplers	11/99
5953-0406	AN 1004	Threshold Sensing for Industrial Control Systems with the HCPL-3700 Interface Optocoupler	11/99
5953-9359	AN 1018	Designing with the HCPL-4100 and HCPL-4200 Current Loop Optocouplers	11/99
5954-1006	AN 1024	Ring Detection with the HCPL-3700 Optocoupler	11/99
5965-5980E	AN 1036	Small Signal Solid State Relays	11/99
5965-5979E	AN 1043	Common-Mode Noise: Sources and Solutions	11/99
5965-5978E	AN 1046	Low On-Resistance Solid State Relays	11/99
5091-6315E	AN 1059	High CMR Isolation Amplifier for Current Sensing	11/99
5965-5977E	AN 1074	Optocoupler Input-Output Endurance Voltage	11/99
5965-5976E	AN 1078	Designing With Avago Technologies Isolation Amplifiers	11/99
5965-5975E	AN 1087	Thermal Data for Optocouplers	11/99
5988-3944EN	AN 1252	Variable Speed Drive Applications in the Consumer Market	20/09/01
5988-3945EN	AN 1253	Variable Speed Drive Applications in the Low-power Industrial Market	20/09/01
5988-3946EN	AN 1254	Variable Speed Drive Applications in the Consumer Market	20/09/01
5988-8267EN	AN 1321	High Speed CMOS Optocouplers Applications in Field Bus Networks	07/11/02

Pub. No	AN No	Title	Pub. Date
5988-8560EN	AN1335	Main Applications and Selection of Gate Driver Optocouplers	09/01/03
5988-9262EN	AN1357	Overview of High Performance Analog Optocouplers	16/04/03
5988-9769EN	AN5004	Design and Applications of HCPL-3020 and HCPL-0302 Gate Drive Optocouplers	25/06/03
5962-6894E	SN 101	Overview of Avago Technologies Optical Isolation Technology and Products for Motor Control Applications	06/96
White Papers: Bullet Proof Industrial Communications			
5980-1297E		Optocouplers for Variable Speed Motor Control Electronics in Consumer Home Appliances	05/00
5988-5076EN		Using 10 and 15 MBd Optocouplers and Optically-isolated Gate Drivers with AC Plasma Display Panel	08/02/02

For product information and a complete list of distributors, please go to our web site:
www.avagotech.com

Avago, Avago Technologies, and the A logo are trademarks of Avago Technologies, Limited in the United States and other countries.
Data subject to change. Copyright © 2006 Avago Technologies, Limited. All rights reserved.
Obsoletes 5988-4082EN
5989-0802EN June 1, 2006

