

HFBR-1506AMZ and HFBR-2506AMZ

16 MBd SMA Transmitter and Receiver for SERCOS Interface



Application Note 5006



Introduction

This application note serves as a guide to provide the designer with information on how to use evaluation kit, HFBR-0541, to design a reliable 16 MBd fiber optic link for SERCOS interface application. The application note relates to the HFBR-1506AMZ and HFBR-2506AMZ optical transmitter and receiver, which are specially designed for SERCOS interface applications. These products can also be used for industrial control data links and applications where reduction of electromagnetic noise susceptibility is needed. Circuit design hints and other information not found in the product data sheets will also be presented. The reader can use this information to design reliable fiber-optic links based on plastic optical fiber (POF) for distances below 45 m and hard clad silica (HCS) fibers for distances below 200 m.

SERCOS (SERial Real-time COmmunication System)

SERCOS provides a standard for high speed serial synchronous signal transfer between the controller and digital drives in real time. By operating in the ring architecture, we can accomplish 2 way (close loop) communication between the system controller and multiple digital drives using Fiber Optic (FO) link.

Why use FO links using Plastic optical Fiber (POF) or Hard clad Silica (HCS)?

Essentially a fiber optic link would score over copper wire, every time there is a high electrical noise environment. Copper transmission media are susceptible to EM fields and emit EM noise which may interfere with other instrumentation. Fiber optic links neither emit nor receive these signals. Because there is no crosstalk between lines, the signal is clearer and bit error rate is reduced. Secondly, the price you pay would be roughly the same as when using Copper wires, despite getting potentially a higher bandwidth and superior performance out of the link. SERCOS utilizes the intrinsic superiority of fiber optics and is able to route all command and feedback signals over the fiber optic network, reducing the wiring requirements drastically. For instance, compared to the traditional analog architecture which required about 150 wires to implement a typical 4 axis control, the SERCOS standard is able to accomplish the same, using less than 10 fiber optic cables. The machine integration time being a fraction of the previous, is one of the many bonuses which you get when using fiber optic based SERCOS.

Components used in a Sercos 16 Mbps FO link:

1. Transmitter (TX) HFBR-1506AMZ: This together with the driver circuitry converts the input TTL compatible electrical signal into optical signal. The optical signal is launched into either 1 mm POF or 200 um HCS, having FSMA connectors.
2. 1 mm POF or 200 um HCS fiber up to a maximum link distance of 45 m or 200 m respectively. If connectors are used to connect the various lengths of fibers, one should account for their insertion loss as well.
3. Receiver (Rx) HFBR-2506AMZ: This converts the input optical signal into TTL compatible electrical signal.

The SERCOS816 IC, which is supplied by ST Microelectronics, is the interface controller for the SERCOS 16 Mbps communications system, and it interfaces between the controller (master) and digital drives (slave), by transmitting and receiving serial data. It drives the Tx and Rx above, by its pins RxD and TxD6-1. For further information about SERCON816 please check www.sercos.com. Figure 1 shows a typical optical link using Avago's latest fiber optic transmitter and receiver.

The connection to the fiber optics is executed by a fiber optic transmitter and a fiber optic receiver. Both are situated in conductive plastic packages, compatible with SMA connectors.

The fiber optic transmitter consists of a 650 nm LED. The SERCOS controller has outputs which provides an adjustable driving current for the transmitter. Together with a RC network between SERCON816 and the transmitter this interface works up to 16 MBd.

Evaluation Kit :

The evaluation kit HFBR-0541 which has the Evaluation board and the components of the SERCOS 16 Mbps FO link, demonstrates, how easy it is to set up a FO link. It's purpose is to help you to easily measure some of the most important performance specifications of the FO components for the aforesaid link.

To simplify matters, instead of using the TxD-1 and RxD, interface pins of SERCON816 IC, which are directly connected to the transmitter through a RC network and the receiver respectively, NAND gates have been used instead. This significantly lowers the cost of the evaluation board. The same biasing arrangement, as recommended by the SERCOS application note 17 (AN17) has been used. You can thus use this evaluation board to ensure that your components would meet the SERCOS specifications.

Transmitter circuit:

Let us first estimate the currents being drawn through the LED in the OFF and ON states. Since the typical output impedance of NAND gates is very low, it is being neglected in comparison to the current limiting resistors R1, R3...R10. The equivalent resistance due to current limiting resistors is $R_{equiv} \approx 81 \text{ ohm}$. Using typical output voltage for Logic 0 level $V_{OL} \approx 0.3 \text{ V}$ and $V_{OH} \approx 4.5$ for Logic 1 level, as per the data sheet, for NAND gates, referring to the equation below and V_f (diode) $\approx 1.8 \text{ V}$, it is easy to compute from Eqn (1) that $I_f \approx 35 \text{ mA}$, when the NAND gates output a logic 0 and less than 1 mA, when they output a logic 1.

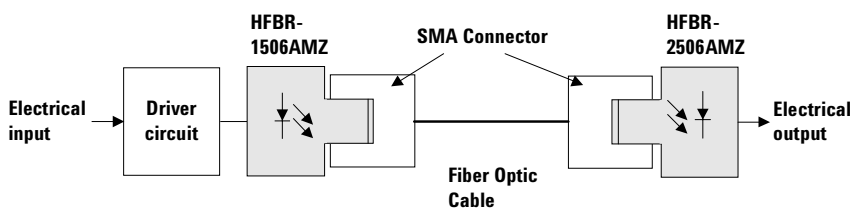

Figure 1. Optical Transmission Line using an Avago Technologies Optical Transmitter and Receiver

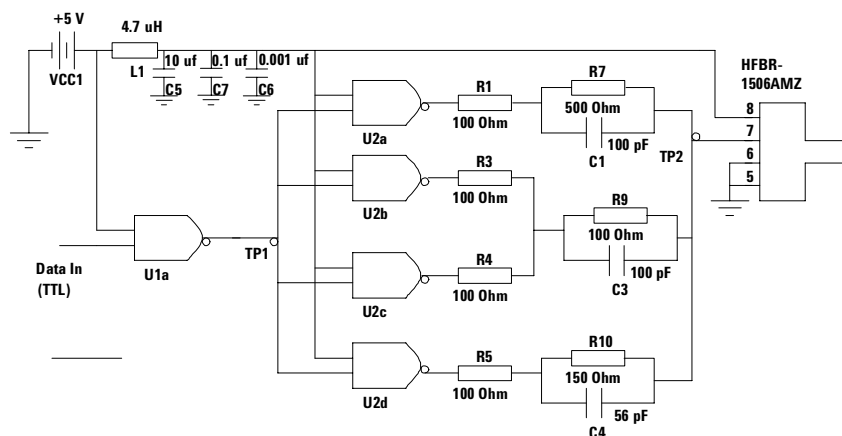

Figure 2. Transmitter circuit

(1)

$$I_f = \frac{V_{CC} - V_{OUT_NAND} - V_f(\text{diode})}{R_{\text{equiv}}}$$

The capacitors C1, C3, C4 in the circuit, provide peaking or pulse shaping current. To understand their action, one can recall from elementary transient circuit theory that a capacitor provides a 'short circuit' while experiencing a transient or rapidly changing voltage level, so the current limiting impedance as seen by the NAND gates is reduced for some time, dependent on the time constant of the RC circuits. This momentary increase in the driver current improves both the rise and fall times of the LED, and thus improves over all Tx performance. Typical Trise and Tfall were observed to be 4 and 2 nsec, with an overshoot of 20%. The variance between high-to-low tPHL and low-to-high tPLH propagation delays of the driver NAND gates contribute to the pulse width distortion (PWD) in the output waveform of the Tx. By using high speed 74ACTQ00 NAND gates, the PWD is expected to be typically less than 3 nsec for the waveform. L1, C5, C6, C7 are the usual power supply filtering elements.

Receiver circuit:

The fiber optic receiver is a "push pull" stage compatible with TTL and CMOS logic. Other than power supply filtering components R11, C8, C9, we do not need any other component for evaluating the Rx.

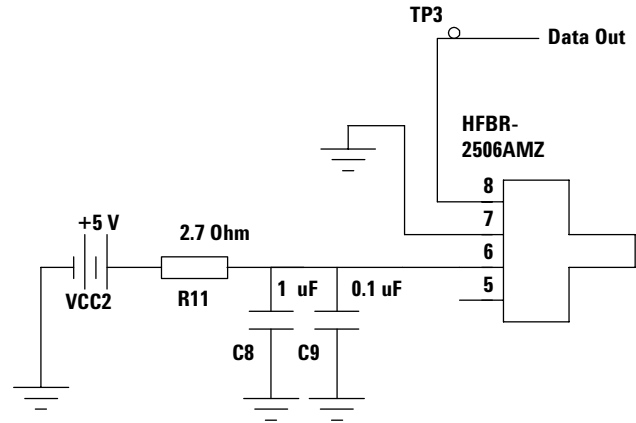

Figure 3. Receiver circuit

Printed Circuit Board Layout

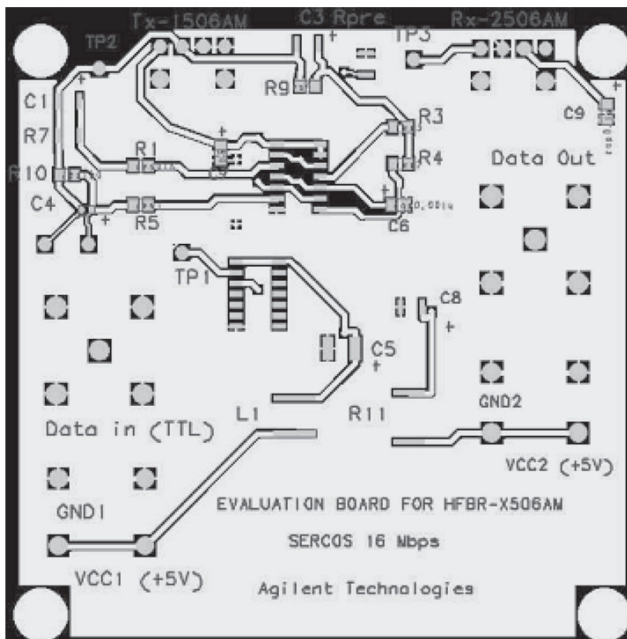

Figure 4. Top Side

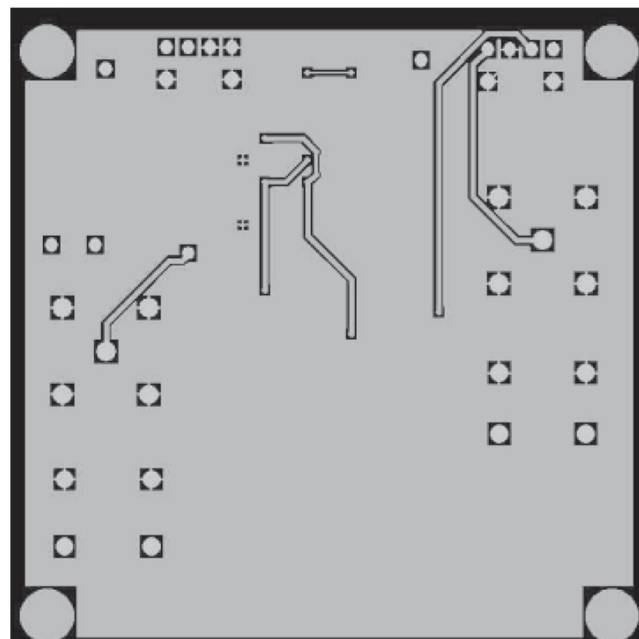

Figure 5. Bottom side

Printed Circuit Board component list

Part No	Description	Footprint
C1, C3	Capacitor 100 pF	1206
C4	Capacitor 56 pF	0603 or 5.08 mm PTH
C5	Capacitor 10 uF / 16 V	Case B
C8	Capacitor 1 uF / 16 V	1206
C9, C7	Capacitor 0.1 uF / 10 V	0805
C6	Capacitor 0.001 uF	0805
L1	Inductor 4.7 uH	1816
R1, R3, R4, R5, R9	Resistor 100 Ohm	0805
R10	Resistor 150 Ohm	0805
R7	Resistor 500 Ohm	1206
R11	Resistor 2.7 Ohm	2512
Rpre	NOT USED	-
TP1, TP2, TP3	Tent Pin	-
VCC1, VCC2, GND1, GND2	Test Jack	-
U1, U2 (ICs)	74ACTQ00SC	SOIC
Tx	HFBR-1506AMZ	-
Rx	HFBR-1506AMZ	-
Data in, Data out	BNC connector (PCB mounting straight)	RS Comp. S/N. 394-1061.

Hookup instructions:

Power supply and signal input:

The transmitter circuit is powered by applying a stabilized +5 V between pins labeled VCC1 and GND. On the receiver side, a second stabilized +5 V supply has to be applied between pins labeled VCC2 and GND. Please note that GND1 and GND2 are interconnected. The signal source has to provide a TTL compatible signal on BNC connector Data in by a 50 ohm Tline cable, the input signal can be verified using a probe on TP1. The output of Rx can be analyzed at TP3 using a probe or at Data Out using the BNC connector. According to the data sheets, a signal between DC and 16 Mbd (8 MHz) can be applied over the specified temperature range.

Additional equipment required:

To analyze the signals, you can use the following equipment:

1. O/E convertor such as the BCP310 or the Newport AD-300-ST series to convert the optical waveform into an electrical one. This should have a good enough a bandwidth, so as not the distort the signal.
2. Oscilloscope such as the Agilent 54615 or Agilent 54622 to see the electrical waveform from the Tx and Rx and measure parameters like Trise, Tfall, and Pulse width distortion etc.
3. 650 nm optical power meter: Agilent 8153A+plugin 81520A, or the NewPort 818 series to measure the LOP.
4. High impedance and high bandwidth probes such as Agilent 1043A or 1160A.
5. Signal generator capable of TTL compatible output for 8 MHz, such as the Agilent 33120

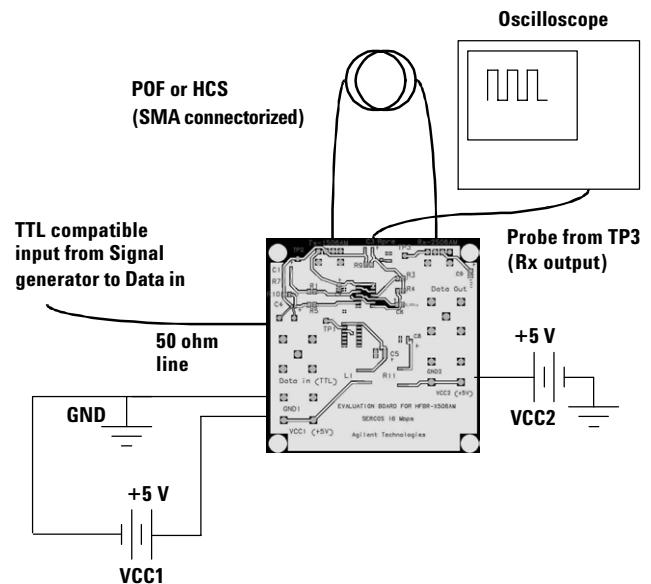

Figure 6. Setup for verifying link performance

Monitoring the signals:

Tx:

You could verify the input signal at Testpoint 1 (TP1) by displaying it on the scope, using a probe. By connecting the output fiber to the O/E convertor and the output from the O/E to the scope, you can measure Trise, Tfall and PWD. You can verify that Trise and Tfall are less than 10 nsec (Typical 4 nsec and 2 nsec respectively). By switching the Data input OFF and by connecting the 1 m length of 1 mm POF (provided in the kit) to the optical power meter to verify that the LOP is within specifications (between -10.5 and -3.5 dBm). Please note that your fiber must have suitable connectorization as the O/E convertor or the optical power meter. The electrical input to the LED can be observed from TP2.

Rx:

By looping back the fiber from the Tx output to the Rx, and making connections as shown in Figure 6, you could display the signal by using a probe at the provided Testpoint3 (TP3). By using various lengths of fibers or by providing external optical attenuation between the Tx and Rx link, you could verify that the Rx has VOH, VOL and PWD are within limits for LOP of -20 dBm in case of 1mm POF and -22 dBm in case of 200 μ m HCS. If you plan to use a BNC cable at Data Out, please note that the Rx is not designed to drive a 50 Ohm load, so might not be within specifications.

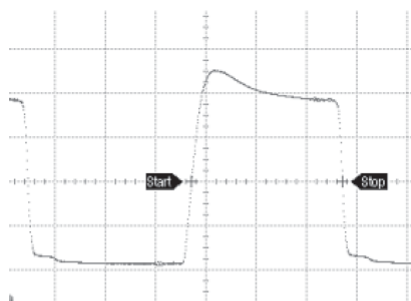

Figure 7. Typical Optical waveform for Tx

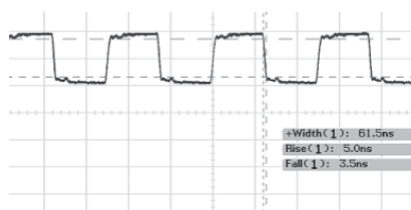

Figure 8. Typical waveform for Rx: Trise and Tfall: 5 and 4 nsec, PWD: 62.5-61.5= \sim 1 nsec. Input LOP is -20 dBm (after passing through an attenuator)

For product information and a complete list of distributors, please go to our web site: www.avagotech.com